



TM_M(GA)_R32_3D INV_EU_NB_2405

FLOOR STANDING R32 3D INVERTER CONTROL

TECHNICAL MANUAL

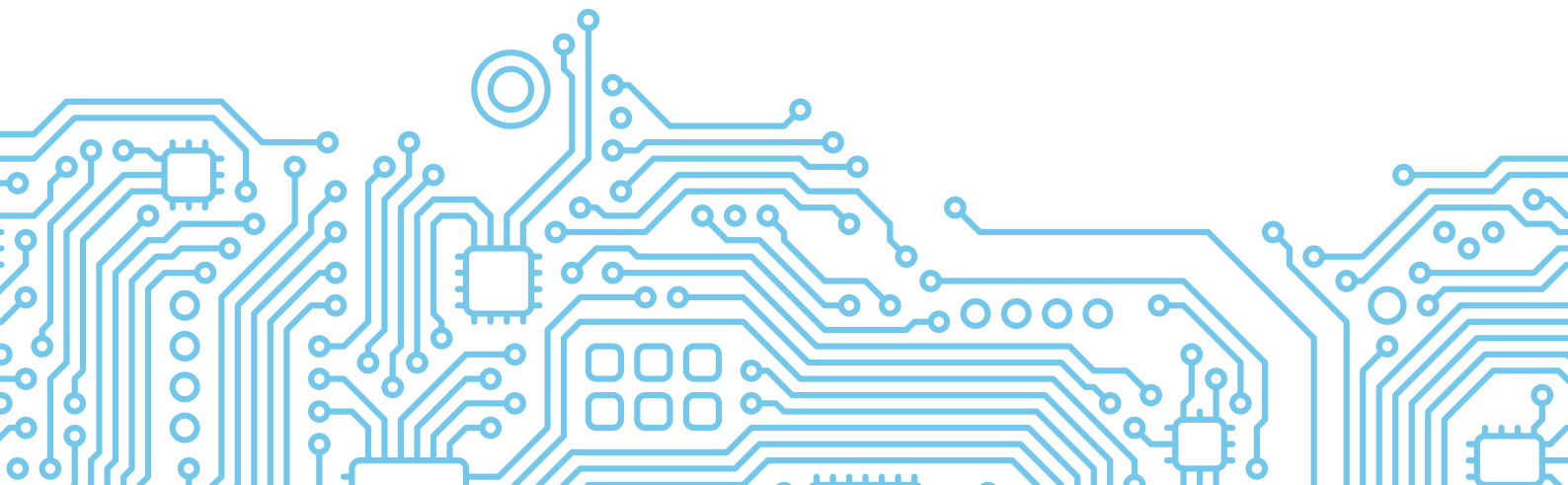
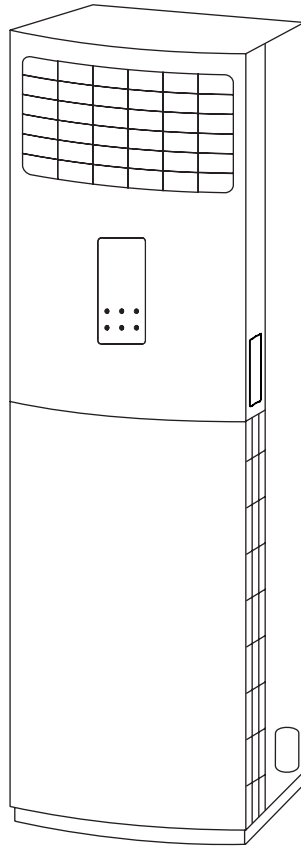

Table of Contents

Page

Specifications	3
1. Model Reference.....	4
2. General Specifications.....	5
3. Dimensional Drawings	9
4. Centre of gravity.....	11
5. Electrical Wiring Diagrams	12
6. Refrigerant Cycle Diagrams	16
7. Capacity Tables	17
8. Capacity Correction Factor for Height Difference	24
9. Noise Criterion Curves	26
10. Electrical Characteristics.....	30
Product Features	31
1. Operation Modes and Functions	32
2. Remoted Controller Functions.....	36
Installation.....	42
Accessories	43
1. Installation Overview.....	44
2. Location selection	45
3. Indoor Unit Installation	46
4. Outdoor unit installation.....	47
5. Drainpipe installation	48
6. Refrigerant Pipe Installation	49
7. Vacuum Drying and Leakage Checking	50
8. Additional Refrigerant Charge	51
9. Engineering of Electrical Wiring	52
10. Test Operation	52

Specifications

Contents

1. Model Reference	4
2. General Specifications	5
3. Dimensional Drawings	9
4. Centre of gravity	11
5. Electrical Wiring Diagrams	12
6. Refrigerant Cycle Diagrams	16
7. Capacity Tables.....	17
8. Capacity Correction Factor for Height Difference	24
9. Noise Criterion Curves.....	26
10. Electrical Characteristics	30

1. Model Reference

Refer to the following table to determine the specific indoor and outdoor unit model number of your purchased equipment.

Indoor Unit Model	Outdoor Unit Model	Capacity (Btu/h)	Power Supply
MFM-48HRFN8-QRD0W	MOX630U-48HFN8-QRD0W(GA)	48k	1Phase, 220~240V, 50Hz
	MOX630U-48HFN8-RRD0W(GA)		3Phase, 380~415V, 50Hz
MFM-55HRFN8-QRD0W	MOX630U-55HFN8-RRD0W(GA)	55k	

2. General Specifications

Model		MFM-48HRFN8-QRD0W(GA)	MFM-48HRFN8-RRC8W(GA)	
Indoor Model		MFM-48HRFN8-QRD0W	MFM-48HRFN8-QRD0W	
Outdoor Model		MOX630U-48HFN8-QRD0W(GA)	MOX630U-48HFN8-RRD0W(GA)	
Power supply	V-Hz-Ph	220-240-1-50	380-415-3-50	
Rated Power Input	W	7300	7300	
Rated Current	A	32.0	14.0	
Starting current	A	/	/	
Compressor	Model	KTQ420D1UMU	KTQ420D1UMU	
	Type	ROTARY	ROTARY	
	Brand	GMCC	GMCC	
	Capacity	W	13700	13700
	Input	W	3700	3700
	Rated current(RLA)	A	7.02	7.02
	Locked rotor Amp(LRA)	A	/	/
	Thermal protector		INT01L-4639	INT01L-4639
	Thermal protector position		EXTERNAL	EXTERNAL
	Capacitor	uF	/	/
Refrigerant oil/oil charge	ml	VG74/1400	VG74/1400	
Indoor fan motor	Model	ZKFN-200-8-1-2	ZKFN-200-8-1-2	
	Input	W	210.0	210.0
	Capacitor	uF	/	/
	Speed(Hi/Mi/Lo)	r/min	580/500/400	580/500/400
Indoor coil	a.Number of rows		3	3
	b.Tube pitch(a)x row pitch(b)	mm	21x13.37	21x13.37
	c.Fin spacing	mm	1.3	1.3
	d.Fin type (code)		Hydrophilic aluminium	Hydrophilic aluminium
	e.Tube outside dia.and type	mm	Φ7,innergroove tube	Φ7,innergroove tube
	f.Coil length x height x width	mm	485x798x40.11	485x798x40.11
	g.Number of circuits		9	9
Indoor air flow (Hi/Mi/Lo)	m ³ /h	2080/1910/1745	2080/1910/1745	
Indoor noise level (Hi/Mi/Lo)	dB(A)	53.5/51.5/49.5/41	53.5/51/49/40.5	
Indoor sound power level	dB(A)	66	66	
Indoor unit	Dimension(W*D*H)	mm	600x455x1934	600x455x1934
	Packing (W*D*H)	mm	2080x755x585	2080x755x585
	Net/Gross weight	Kg	58.6/77.5	58.6/77.5
Outdoor fan motor	Model	ZKFN-250-10-1	ZKFN-250-10-1	
	Input	W	270	270
	Capacitor	uF	/	/
	Speed	r/min	850/400	850/400
Outdoor coil	a.Number of rows		2.6	2.6
	b.Tube pitch(a)x row pitch(b)	mm	21x22	21x22
	c.Fin spacing	mm	1.3	1.3
	d.Fin type (code)		Hydrophilic aluminium	Hydrophilic aluminium
	e.Tube outside dia.and type	mm	Φ7,innergroove tube	Φ7,innergroove tube
	f.Coil length x height x width	mm	990*924*66	990*924*66
	g.Number of circuits		14	14
Outdoor air flow	m ³ /h	5600	5600	
Outdoor noise level	dB(A)	65	65	
Outdoor sound power level	dB(A)	72	72	
Outdoor unit	Dimension(W*D*H)	mm	980x415x975	980x415x975
	Packing (W*D*H)	mm	1145x500x1080	1145x500x1080
	Net/Gross weight	Kg	82.5/97	90/105

Refrigerant	Type		R32	R32
	GWP		675	675
	Charged quantity	kg	2.9	2.9
Design pressure		MPa	4.3/1.7	4.3/1.7
Refrigerant piping	Liquid side/ Gas side	mm(inch)	φ9.52/φ15.9(3/8"/5/8")	φ9.52/φ15.9(3/8"/5/8")
	Max. refrigerant pipe length	m	75	75
	Max. difference in level	m	30	30
Connection wiring			1.5x4	1.5x4
Plug type			6.0x3/no-plug	2.5x5/no-plug
Thermostat type			Remote Control	Remote Control
Operation temperature		C	17-30	17-30
Room temperature	Indoor(cooling/ heating)	C	17-32/0-30	17-32/0-30
	Outdoor(cooling/heating)	C	-15-50/-20-24	-15-50/-20-24
Qty/per 20' /40' /40'HQ			18/40/40	18/40/40

Notes:

1) Capacities are based on the following conditions:

Cooling(T1): - Indoor Temperature 27°C(80.6°F) DB /19 °C(66.2°F) WB

-Outdoor Temperature 35 °C(95°F) DB /24 °C(75.2°F) WB

-Interconnecting Piping Length 5m

- Level Difference of Zero.

Heating: - Indoor Temperature 20°C(68°F) DB / 15°C(59°F) WB

-Outdoor Temperature 7°C(44.6°F) DB / 6°C(42.8°F) WB

- Interconnecting Piping Length 5 m

- Level Difference of Zero.

2) Capacities are Net Capacities.

3) Due to our policy of innovation some specifications may be changed without notification.

Model		MFM-55HRFN8-RRDOW(GA)	
Indoor Model		MFM-55HRFN8-QRDOW	
Outdoor Model		MOX630U-55HFN8-RRDOW(GA)	
Power supply		V-Hz-Ph	380-415-3-50
Rated Power Input		W	7500
Rated Current		A	14.0
Starting current		A	
Compressor	Model	KTQ420D1UMU	
	Type	ROTARY	
	Brand	GMCC	
	Capacity	W	13700
	Input	W	3700
	Rated current(RLA)	A	7.02
	Locked rotor Amp(LRA)	A	/
	Thermal protector	INT01L-4639	
	Thermal protector position	EXTERNAL	
	Capacitor	uF	/
	Refrigerant oil/oil charge	ml	VG74/1400
Indoor fan motor	Model	ZKFN-200-8-1-2	
	Input	W	210.0
	Capacitor	uF	/
	Speed(Hi/Mi/Lo)	r/min	580/500/400
Indoor coil	a.Number of rows	3	
	b.Tube pitch(a)x row pitch(b)	mm	25.4x22
	c.Fin spacing	mm	1.5
	d.Fin type (code)	Hydrophilic aluminium	
	e.Tube outside dia.and type	mm	Φ9.52,innergroove tube
	f.Coil length x height x width	mm	484.4x813x66
	g.Number of circuits	6	
Indoor air flow (Hi/Mi/Lo)		m ³ /h	1950/1750/1600
Indoor noise level (Hi/Mi/Lo)		dB(A)	53/50.5/45.5/40
Indoor sound power level		dB(A)	64
Indoor unit	Dimension(W*D*H)	mm	600x455x1934
	Packing (W*D*H)	mm	2080x755x585
	Net/Gross weight	Kg	61.4/80.0
Outdoor fan motor	Model	ZKFN-250-10-1	
	Input	W	270
	Capacitor	uF	/
	Speed	r/min	850/400
Outdoor coil	a.Number of rows	3	
	b.Tube pitch(a)x row pitch(b)	mm	21x22
	c.Fin spacing	mm	1.3
	d.Fin type (code)	Hydrophilic aluminium	
	e.Tube outside dia.and type	mm	Φ7,innergroove tube
	f.Coil length x height x width	mm	990*924*66
	g.Number of circuits	14	
Outdoor air flow		m ³ /h	5600
Outdoor noise level		dB(A)	65
Outdoor sound power level		dB(A)	73
Outdoor unit	Dimension(W*D*H)	mm	980x415x975
	Packing (W*D*H)	mm	1145x500x1080
	Net/Gross weight	Kg	92/107
Refrigerant	Type	R32	
	GWP	675	
	Charged quantity	kg	3.2

Design pressure		MPa	4.3/1.7
Refrigerant piping	Liquid side/ Gas side	mm(inch)	$\phi 9.52/\phi 15.9(3/8''/5/8'')$
	Max. refrigerant pipe length	m	75
	Max. difference in level	m	30
Connection wiring			1.5x4
Plug type			2.5x5/no-plug
Thermostat type			Remote Control
Operation temperature		C	17-30
Room temperature	Indoor(cooling/ heating)	C	17-32/0-30
	Outdoor(cooling/heating)	C	-15-50/-20-24
Qty/per 20' /40' /40'HQ			18/40/40

Notes:

1) Capacities are based on the following conditions:

Cooling(T1): - Indoor Temperature 27°C(80.6°F) DB /19 °C(66.2°F) WB Heating: - Indoor Temperature 20°C(68°F) DB / 15°C(59°F) WB

-Outdoor Temperature 35 °C(95°F) DB /24 °C(75.2°F) WB

-Outdoor Temperature 7°C(44.6°F) DB / 6°C(42.8°F) WB

-Interconnecting Piping Length 5m

- Interconnecting Piping Length 5 m

- Level Difference of Zero.

- Level Difference of Zero.

2) Capacities are Net Capacities.

3) Due to our policy of innovation some specifications may be changed without notification.

3. Dimensional Drawings

Indoor Unit

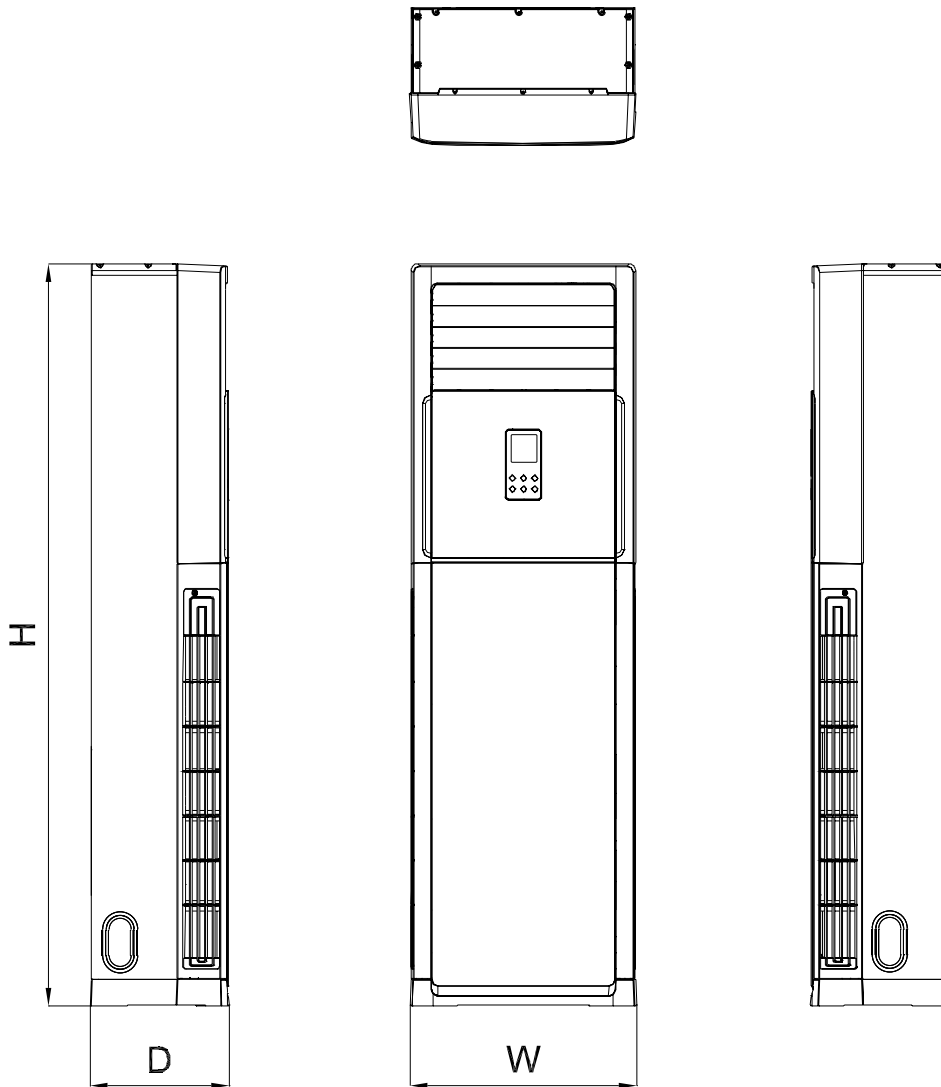

Capacity(Btu/h)	W(mm)	D(mm)	H(mm)
48k/55k	600	455	1934

Outdoor Unit

MOX630U-48HFN8-QRD0W(GA), MOX630U-48HFN8-RRD0W(GA), MOX630U-55HFN8-RRD0W(GA)

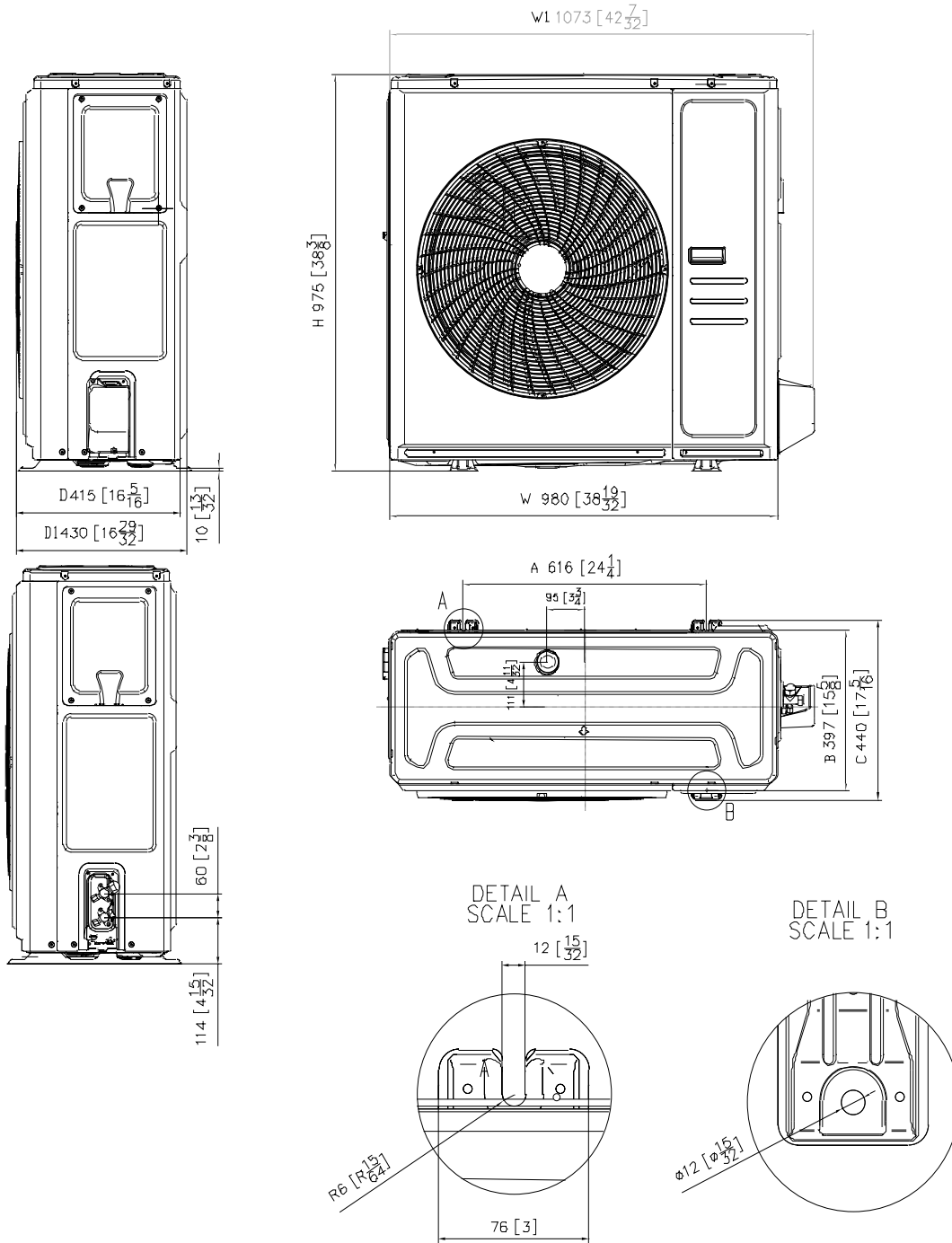

4. Centre of gravity

MOX630U-48HFN8-QRD0W(GA), MOX630U-48HFN8-RRD0W(GA), MOX630U-55HFN8-RRD0W(GA)

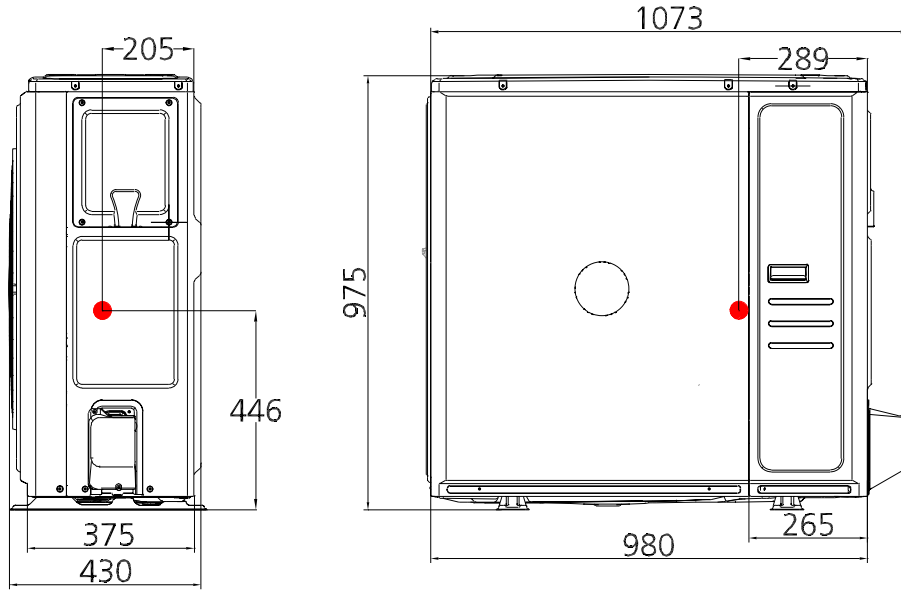

5. Electrical Wiring Diagrams

5.1 Indoor unit

Abbreviation	Paraphrase
Y/G	Yellow-Green Conductor
HOR-SW	Horizontal Fan
VER-AC MOTOR,VER-DC MOTOR	Vertical Fan
L or 1	LIVE
2(N)	NEUTRAL
T1	Indoor Room Temperature
T2	Coil Temperature of Indoor Heat Exchanger

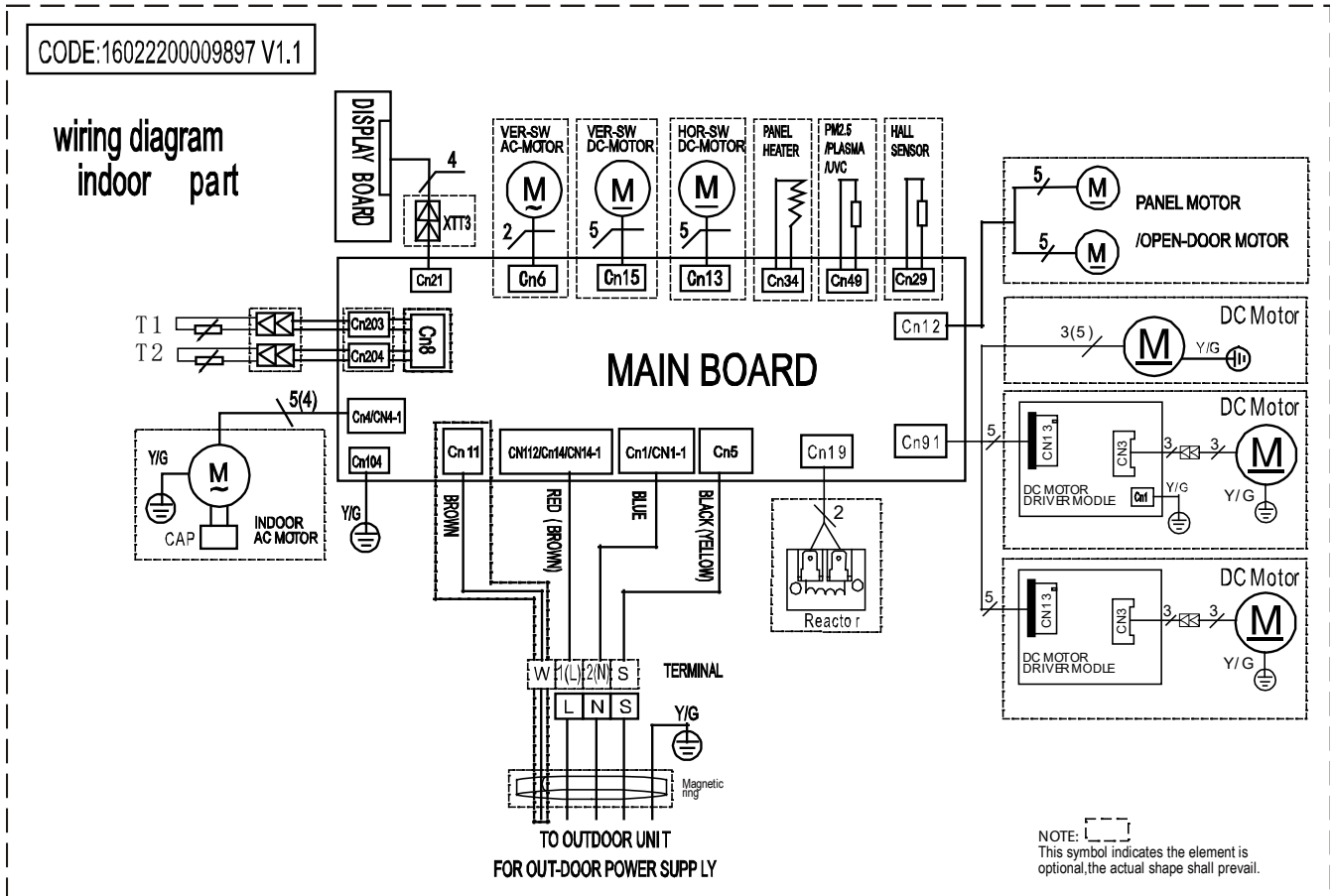

5.2 Outdoor Unit

Abbreviation	Paraphrase
COMP	Compressor
CAP1,CAP2	Fan Motor Capacitor
CT1	AC Current Detector
EEV	Electric Expansion Valve
DC FAN1,DC FAN2	Outdoor DC Fan
AC FAN1,AC FAN2	Outdoor AC Fan
HEAT_Y,HEAT_D	Crankcase Heating
H-PRO	High Pressure Switch
L-PRO	Low Pressure Switch
SV	4-Way Valve
TP	Exhaust Temperature Sensor
T3	Condenser Temperature Sensor
T4	Outdoor Ambient Temperature Sensor
TH	Heatsink Temperature Sensor
CN1-CN17	P.C Board Sockets

Notes:
This symbol indicates the element is optional, the actual shape shall be prevail.

CODE	PART NAME
COMP	COMPRESSOR
CT1	
EEV	ELECTRONIC EXPANSION VALVE
FM1	OUTDOOR DC FAN MOTOR
HEAT_D	CHASSIS HEATER
HEAT_Y	CRANKCASE HEATER
H-PRO	HIGH PRESSURE SWITCH
L-PRO	LOW PRESSURE SWITCH
SV	REVERSE VALVE
TP	COMP. DISCHARGE TEMP. SENSOR
T3	COIL TEMP. SENSOR
T4	OUTDOOR AMBIENT TEMP. SENSOR
COMP TOP	COMP. TOP OLP TEMP. SENSOR

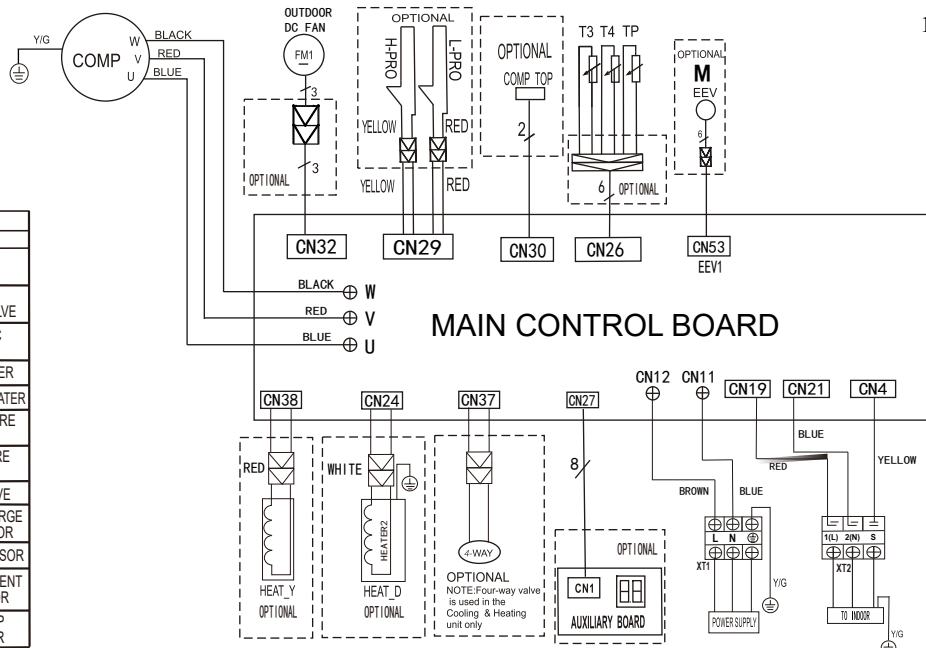

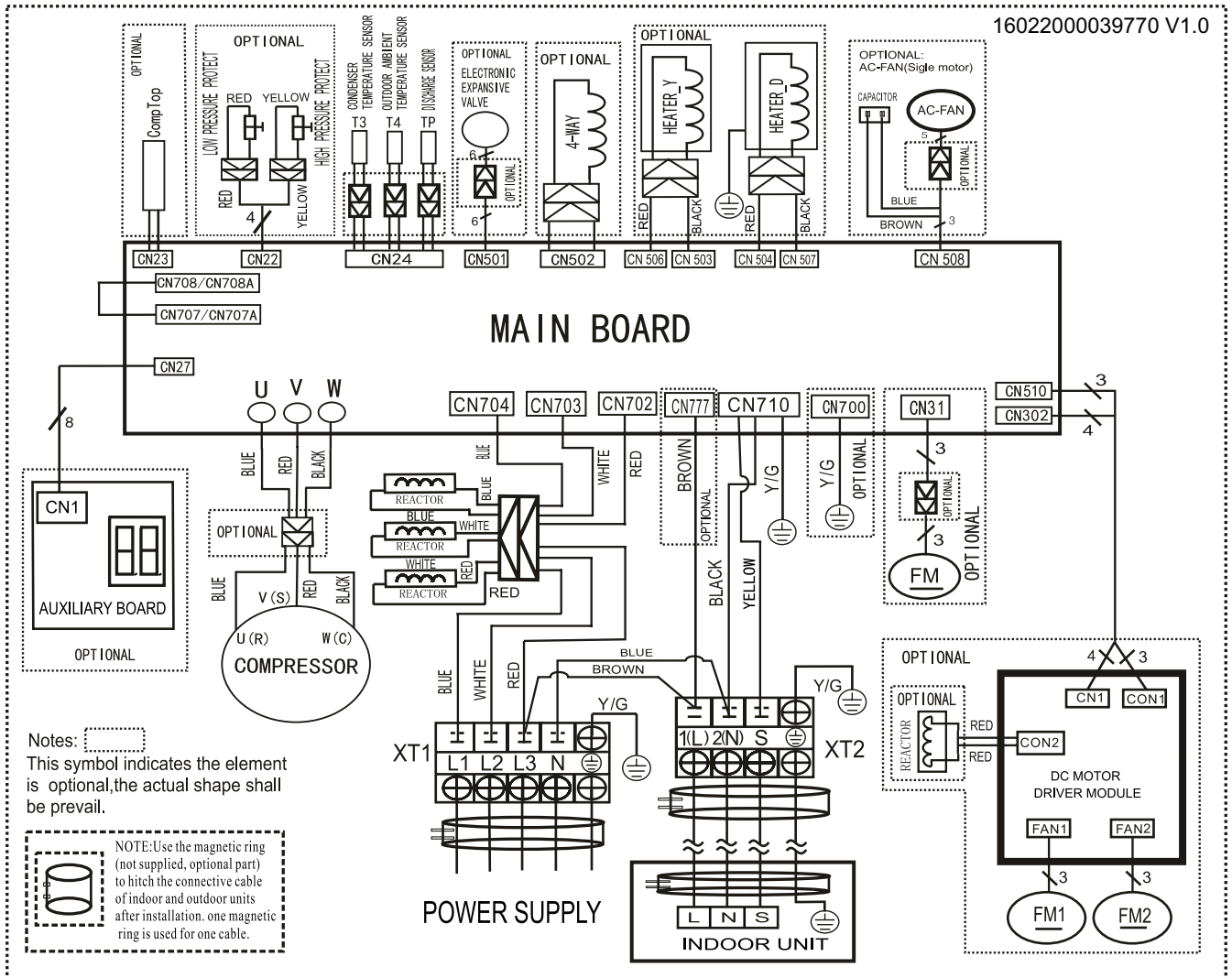

6. Refrigerant Cycle Diagrams

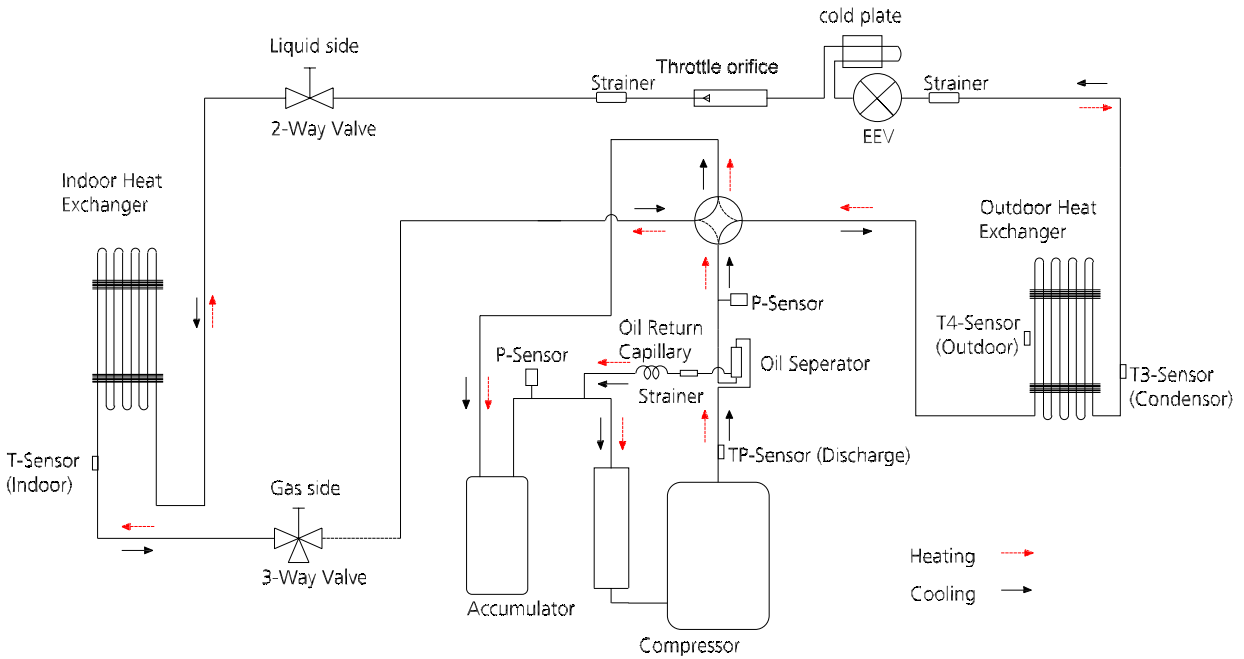

Capacity(Btu/h)	Pipe Size (Diameter:ø) mm(inch)		Piping length(m/ft)		Elevation(m/ft)		Additional Refrigerant
	Gas	Liquid	Rated	Max.	Rated	Max.	
48k/55k	15.9(5/8)	9.52(3/8)	5/16.4	75m(246ft)	0	30/98.4	24g/m (0.26oz/ft)

7. Capacity Tables

7.1 Cooling

		48k(1Ph&3Ph)																
INDOOR AIRFLOW (CMH)	OUTDOOR DB (C)	ID WB (C)	16.0				18.0				19.0				22.0			
		ID DB (C)	23.0	25.0	27.0	30.0	23.0	25.0	27.0	30.0	23.0	25.0	27.0	30.0	23.0	25.0	27.0	30.0
1745	-15	TC	11.17	11.19	11.20	11.22	11.85	11.86	11.87	11.89	12.55	12.57	12.58	12.60	13.31	13.33	13.34	13.36
		S/T	0.43	0.51	0.58	0.66	0.46	0.54	0.61	0.70	0.49	0.57	0.65	0.74	0.52	0.61	0.69	0.79
		PI	2.39	2.39	2.39	2.40	2.53	2.53	2.54	2.54	2.68	2.69	2.69	2.69	2.84	2.85	2.85	2.85
	-10	TC	11.17	11.19	11.20	11.22	11.85	11.86	11.87	11.89	12.55	12.57	12.58	12.60	13.31	13.33	13.34	13.36
		S/T	0.44	0.51	0.58	0.66	0.46	0.54	0.62	0.70	0.49	0.57	0.65	0.74	0.52	0.61	0.69	0.79
		PI	2.30	2.30	2.31	2.31	2.44	2.44	2.45	2.45	2.59	2.59	2.59	2.60	2.74	2.74	2.75	2.75
	-5	TC	11.17	11.19	11.20	11.22	11.85	11.86	11.87	11.89	12.55	12.57	12.58	12.60	13.31	13.33	13.34	13.36
		S/T	0.44	0.52	0.59	0.67	0.47	0.55	0.62	0.71	0.49	0.58	0.66	0.75	0.52	0.61	0.70	0.79
		PI	2.20	2.20	2.20	2.21	2.33	2.33	2.33	2.34	2.47	2.47	2.47	2.48	2.62	2.62	2.62	2.63
	0	TC	11.17	11.19	11.20	11.22	11.85	11.86	11.87	11.89	12.55	12.57	12.58	12.60	13.31	13.33	13.34	13.36
		S/T	0.44	0.52	0.59	0.67	0.47	0.55	0.62	0.71	0.50	0.58	0.66	0.75	0.53	0.62	0.70	0.80
		PI	2.08	2.09	2.09	2.09	2.21	2.21	2.21	2.22	2.34	2.34	2.35	2.35	2.48	2.48	2.49	2.49
	5	TC	11.17	11.19	11.20	11.22	11.85	11.86	11.87	11.89	12.55	12.57	12.58	12.60	13.31	13.33	13.34	13.36
		S/T	0.44	0.52	0.59	0.67	0.47	0.55	0.62	0.71	0.50	0.58	0.66	0.75	0.53	0.62	0.70	0.80
		PI	1.91	1.91	1.91	1.91	2.02	2.02	2.02	2.03	2.14	2.14	2.15	2.15	2.27	2.27	2.28	2.28
	10	TC	11.17	11.19	11.20	11.22	11.85	11.86	11.87	11.89	12.55	12.57	12.58	12.60	13.31	13.33	13.34	13.36
		S/T	0.45	0.52	0.59	0.68	0.47	0.55	0.63	0.72	0.50	0.59	0.67	0.76	0.53	0.62	0.71	0.81
		PI	1.83	1.83	1.83	1.83	1.94	1.94	1.94	1.94	2.05	2.06	2.06	2.06	2.18	2.18	2.18	2.18
	15	TC	11.17	11.19	11.20	11.22	11.85	11.86	11.87	11.89	12.55	12.57	12.58	12.60	13.31	13.33	13.34	13.36
		S/T	0.45	0.53	0.60	0.68	0.47	0.56	0.63	0.72	0.50	0.59	0.67	0.76	0.53	0.63	0.71	0.81
		PI	2.01	2.01	2.01	2.02	2.13	2.13	2.14	2.14	2.26	2.26	2.26	2.27	2.39	2.40	2.40	2.40
	20	TC	11.17	11.19	11.20	11.22	11.85	11.86	11.87	11.89	12.55	12.57	12.58	12.60	13.31	13.33	13.34	13.36
		S/T	0.46	0.54	0.61	0.70	0.49	0.57	0.65	0.74	0.52	0.61	0.69	0.79	0.55	0.64	0.73	0.83
		PI	2.19	2.20	2.20	2.20	2.32	2.33	2.33	2.33	2.46	2.47	2.47	2.47	2.61	2.61	2.62	2.62
	25	TC	11.17	11.19	11.20	11.22	11.85	11.86	11.87	11.89	12.55	12.57	12.58	12.60	13.31	13.33	13.34	13.36
		S/T	0.47	0.55	0.62	0.71	0.49	0.58	0.66	0.75	0.52	0.61	0.70	0.80	0.55	0.65	0.74	0.84
		PI	2.37	2.38	2.38	2.38	2.52	2.52	2.52	2.53	2.67	2.67	2.67	2.68	2.83	2.83	2.84	2.84
	30	TC	11.17	11.19	11.20	11.22	11.85	11.86	11.87	11.89	12.55	12.57	12.58	12.60	13.31	13.33	13.34	13.36
		S/T	0.48	0.56	0.64	0.73	0.51	0.59	0.68	0.77	0.54	0.63	0.72	0.82	0.57	0.67	0.76	0.86
		PI	3.05	3.05	3.05	3.06	3.23	3.23	3.24	3.24	3.42	3.43	3.43	3.44	3.63	3.63	3.64	3.64
	35	TC	11.17	11.19	11.20	11.22	11.85	11.86	11.87	11.89	12.55	12.57	12.58	12.60	13.31	13.33	13.34	13.36
		S/T	0.48	0.56	0.64	0.73	0.51	0.59	0.68	0.77	0.54	0.63	0.72	0.82	0.57	0.67	0.76	0.86
		PI	3.97	3.98	3.98	3.99	4.21	4.22	4.22	4.23	4.46	4.47	4.47	4.48	4.73	4.74	4.74	4.75
	40	TC	9.69	9.70	9.71	9.73	10.27	10.28	10.29	10.31	10.89	10.90	10.91	10.93	11.54	11.55	11.57	11.58
		S/T	0.49	0.57	0.65	0.74	0.52	0.61	0.69	0.79	0.55	0.65	0.73	0.84	0.58	0.68	0.78	0.89
		PI	3.53	3.53	3.54	3.54	3.74	3.75	3.75	3.75	3.96	3.97	3.97	3.98	4.20	4.21	4.21	4.22
	45	TC	7.49	7.50	7.51	7.52	7.95	7.95	7.96	7.97	8.42	8.43	8.44	8.45	8.93	8.94	8.95	8.96
		S/T	0.51	0.60	0.68	0.78	0.54	0.64	0.73	0.83	0.58	0.68	0.77	0.88	0.61	0.72	0.82	0.93
		PI	2.90	2.90	2.91	2.91	3.07	3.08	3.08	3.08	3.26	3.26	3.27	3.27	3.45	3.46	3.46	3.47
	50	TC	4.24	4.24	4.25	4.25	4.49	4.50	4.50	4.51	4.76	4.77	4.77	4.78	5.05	5.05	5.06	5.06
		S/T	0.53	0.62	0.70	0.80	0.56	0.65	0.74	0.85	0.59	0.69	0.79	0.90	0.63	0.73	0.83	0.95
		PI	1.99	1.99	2.00	2.00	2.11	2.11	2.12	2.12	2.24	2.24	2.24	2.25	2.37	2.38	2.38	2.38

Specifications

INDOOR AIRFLOW (CMH)	OUTDOOR DB(C)	ID WB (C)	55k																
			ID DB (C)	16.0				18.0				19.0				22.0			
				23.0	25.0	27.0	30.0	23.0	25.0	27.0	30.0	23.0	25.0	27.0	30.0	23.0	25.0	27.0	30.0
1600	-15	TC	11.56	11.58	11.59	11.61	12.26	12.27	12.28	12.30	12.99	13.01	13.02	13.04	13.77	13.79	13.80	13.82	
		S/T	0.42	0.49	0.55	0.63	0.44	0.52	0.59	0.67	0.47	0.55	0.62	0.71	0.49	0.58	0.66	0.75	
		PI	2.74	2.74	2.74	2.75	2.90	2.90	2.91	2.91	3.07	3.08	3.08	3.09	3.26	3.26	3.27	3.27	
	-10	TC	11.56	11.58	11.59	11.61	12.26	12.27	12.28	12.30	12.99	13.01	13.02	13.04	13.77	13.79	13.80	13.82	
		S/T	0.42	0.49	0.55	0.63	0.44	0.52	0.59	0.67	0.47	0.55	0.62	0.71	0.50	0.58	0.66	0.75	
		PI	2.64	2.64	2.64	2.65	2.80	2.80	2.80	2.81	2.96	2.97	2.97	2.98	3.14	3.15	3.15	3.15	
	-5	TC	11.56	11.58	11.59	11.61	12.26	12.27	12.28	12.30	12.99	13.01	13.02	13.04	13.77	13.79	13.80	13.82	
		S/T	0.42	0.49	0.56	0.64	0.44	0.52	0.59	0.68	0.47	0.55	0.63	0.72	0.50	0.59	0.67	0.76	
		PI	2.52	2.52	2.52	2.53	2.67	2.67	2.68	2.68	2.83	2.83	2.84	2.84	3.00	3.00	3.01	3.01	
	0	TC	11.56	11.58	11.59	11.61	12.26	12.27	12.28	12.30	12.99	13.01	13.02	13.04	13.77	13.79	13.80	13.82	
		S/T	0.42	0.49	0.56	0.64	0.45	0.52	0.60	0.68	0.47	0.56	0.63	0.72	0.50	0.59	0.67	0.76	
		PI	2.39	2.39	2.39	2.40	2.53	2.53	2.54	2.54	2.68	2.69	2.69	2.69	2.84	2.85	2.85	2.85	
	5	TC	11.56	11.58	11.59	11.61	12.26	12.27	12.28	12.30	12.99	13.01	13.02	13.04	13.77	13.79	13.80	13.82	
		S/T	0.42	0.50	0.56	0.64	0.45	0.53	0.60	0.68	0.47	0.56	0.63	0.72	0.50	0.59	0.67	0.76	
		PI	2.18	2.19	2.19	2.19	2.32	2.32	2.32	2.32	2.45	2.46	2.46	2.46	2.60	2.60	2.61	2.61	
	10	TC	11.56	11.58	11.59	11.61	12.26	12.27	12.28	12.30	12.99	13.01	13.02	13.04	13.77	13.79	13.80	13.82	
		S/T	0.43	0.50	0.57	0.65	0.45	0.53	0.60	0.69	0.48	0.56	0.64	0.73	0.51	0.59	0.68	0.77	
		PI	2.09	2.10	2.10	2.10	2.22	2.22	2.23	2.23	2.35	2.36	2.36	2.36	2.50	2.50	2.50	2.50	
	15	TC	11.56	11.58	11.59	11.61	12.26	12.27	12.28	12.30	12.99	13.01	13.02	13.04	13.77	13.79	13.80	13.82	
		S/T	0.43	0.50	0.57	0.65	0.45	0.53	0.60	0.69	0.48	0.56	0.64	0.73	0.51	0.60	0.68	0.77	
		PI	2.30	2.31	2.31	2.31	2.44	2.45	2.45	2.45	2.59	2.59	2.59	2.60	2.74	2.75	2.75	2.75	
	20	TC	11.56	11.58	11.59	11.61	12.26	12.27	12.28	12.30	12.99	13.01	13.02	13.04	13.77	13.79	13.80	13.82	
		S/T	0.44	0.52	0.59	0.67	0.47	0.55	0.62	0.71	0.49	0.58	0.66	0.75	0.52	0.61	0.70	0.80	
		PI	2.51	2.52	2.52	2.52	2.66	2.67	2.67	2.67	2.82	2.83	2.83	2.83	2.99	3.00	3.00	3.00	
	25	TC	11.56	11.58	11.59	11.61	12.26	12.27	12.28	12.30	12.99	13.01	13.02	13.04	13.77	13.79	13.80	13.82	
		S/T	0.44	0.52	0.59	0.68	0.47	0.55	0.63	0.72	0.50	0.59	0.67	0.76	0.53	0.62	0.71	0.81	
		PI	2.72	2.73	2.73	2.73	2.89	2.89	2.89	2.90	3.06	3.06	3.07	3.07	3.24	3.25	3.25	3.25	
	30	TC	11.56	11.58	11.59	11.61	12.26	12.27	12.28	12.30	12.99	13.01	13.02	13.04	13.77	13.79	13.80	13.82	
		S/T	0.46	0.54	0.61	0.69	0.48	0.57	0.64	0.74	0.51	0.60	0.68	0.78	0.54	0.64	0.72	0.83	
		PI	3.49	3.50	3.50	3.51	3.70	3.71	3.71	3.72	3.92	3.93	3.93	3.94	4.16	4.16	4.17	4.18	
	35	TC	11.56	11.58	11.59	11.61	12.26	12.27	12.28	12.30	12.99	13.01	13.02	13.04	13.77	13.79	13.80	13.82	
		S/T	0.46	0.54	0.61	0.69	0.48	0.57	0.64	0.74	0.51	0.60	0.68	0.78	0.54	0.64	0.72	0.83	
		PI	4.55	4.56	4.56	4.57	4.83	4.83	4.84	4.84	5.11	5.12	5.13	5.13	5.42	5.43	5.43	5.44	
	40	TC	10.02	10.04	10.05	10.06	10.63	10.64	10.65	10.67	11.26	11.28	11.29	11.31	11.94	11.96	11.97	11.99	
		S/T	0.47	0.55	0.62	0.71	0.50	0.58	0.66	0.75	0.53	0.62	0.70	0.80	0.56	0.65	0.74	0.85	
		PI	4.04	4.05	4.05	4.06	4.29	4.29	4.30	4.30	4.54	4.55	4.55	4.56	4.82	4.82	4.83	4.83	
	45	TC	7.75	7.76	7.77	7.78	8.22	8.23	8.24	8.25	8.71	8.72	8.73	8.74	9.24	9.25	9.26	9.27	
		S/T	0.49	0.58	0.65	0.75	0.52	0.61	0.69	0.79	0.55	0.65	0.73	0.84	0.58	0.69	0.78	0.89	
		PI	3.32	3.33	3.33	3.34	3.52	3.53	3.53	3.54	3.73	3.74	3.74	3.75	3.96	3.96	3.97	3.97	
	50	TC	4.38	4.39	4.39	4.40	4.65	4.65	4.66	4.66	4.92	4.93	4.94	4.94	5.22	5.23	5.23	5.24	
		S/T	0.50	0.59	0.67	0.76	0.53	0.62	0.71	0.81	0.56	0.66	0.75	0.86	0.60	0.70	0.80	0.91	
		PI	2.28	2.29	2.29	2.29	2.42	2.42	2.43	2.43	2.56	2.57	2.57	2.57	2.72	2.72	2.73	2.73	
	1750	-15	TC	12.51	12.52	12.54	12.56	13.26	13.28	13.29	13.31	14.05	14.07	14.09	14.11	14.90	14.92	14.93	14.95
			S/T	0.45	0.53	0.60	0.68	0.48	0.56	0.63	0.72	0.50	0.59	0.67	0.77	0.53	0.63	0.71	0.81
			PI	2.96	2.96	2.97	2.97	3.14	3.14	3.14	3.15	3.33	3.33	3.33	3.34	3.53	3.53	3.53	3.54
		-10	TC	12.51	12.52	12.54	12.56	13.26	13.28	13.29	13.31	14.05	14.07	14.09	14.11	14.90	14.92	14.93	14.95
			S/T	0.45	0.53	0.60	0.68	0.48	0.56	0.64	0.72	0.51	0.59	0.67	0.77	0.54	0.63	0.71	0.81
			PI	2.85	2.86	2.86	2.86	3.03	3.03	3.03	3.04	3.21	3.21	3.21	3.22	3.40	3.40	3.41	3.41
		-5	TC	12.51	12.52	12.54	12.56	13.26	13.28	13.29	13.31	14.05	14.07	14.09	14.11	14.90	14.92	14.93	14.95
			S/T	0.45	0.53	0.60	0.69	0.48	0.56	0.64	0.73	0.51	0.60	0.68	0.77	0.54	0.63	0.72	0.82
			PI	2.72	2.73	2.73	2.73	2.89	2.89	2.89	2.90	3.06	3.06	3.07	3.07	3.25	3.25	3.25	3.26
		0	TC	12.51	12.52	12.54	12.56	13.26	13.28	13.29	13.31	14.05	14.07	14.09	14.11	14.90	14.92	14.93	14.95
			S/T	0.46	0.53	0.61	0.69	0.48	0.57	0.64	0.73	0.51	0.60	0.68	0.78	0.54	0.64	0.72	0.83
			PI	2.58	2.59	2.59	2.59	2.74	2.74	2.74	2.75	2.90	2.91	2.91	2.91	3.08	3.08	3.08	3.09
5		TC	12.51	12.52	12.54	12.56	13.26	13.28	13.29	13.31	14.05	14.07	14.09	14.11	14.90	14.92	14.93	14.95	
		S/T	0.46	0.54	0.61	0.69	0.48	0.57	0.65	0.74	0.51	0.60	0.68	0.78	0.54	0.64	0.73	0.83	
		PI	2.36	2.37	2.37	2.37	2.51	2.51	2.51	2.51	2.65	2.66	2.66	2.66	2.81	2.82	2.82	2.83	
10		TC	12.51	12.52	12.54	12.56	13.26	13.28	13.29	13.31	14.05	14.07	14.09	14.11	14.90	14.92	14.93	14.95	
		S/T	0.46	0.54	0.61	0.70	0.49	0.57	0.65	0.74	0.52	0.61	0.69	0.79	0.55	0.64	0.73	0.83	
		PI	2.27	2.27	2.27	2.27	2.40	2.41	2.41	2.41	2.55	2.55	2.55	2.56	2.70	2.70	2.71	2.71	
15		TC	12.51	12.52	12.54	12.56	13.26	13.28	13.29	13.31	14.05	14.07	14.09	14.11	14.90	14.92	14.93	14.95	
		S/T	0.46	0.54	0.62	0.70	0.49	0.58	0.65	0.75	0.52	0.61	0.69	0.79	0.55	0.65	0.73	0.84	
		PI	2.49	2.50	2.50	2.50	2.64	2.65	2.65	2.65	2.80	2.80	2.81	2.81	2.97	2.97	2.98	2.98	
20		TC	12.51	12.52	12.54	12.56	13.26	13.28	13.29	13.31	14.05	14.07	14.09	14.11	14.90	14.92	14.93	14.95	
		S/T	0.48	0.56	0.63	0.72	0.50	0.59	0.67	0.77	0.53	0.63	0.71	0.81	0.57	0.66	0.75	0.86	
		PI	2.72	2.72	2.72	2.73	2.88	2.89	2.89	2.89	3.05	3.06	3.06	3.07	3.24	3.24	3.25	3.25	
25		TC	12.51	12.52	12.54	12.56	13.26	13.28	13.29	13.31	14.05	14.07	14.09	14.11	14.90	14.92	14.93	14.95	
		S/T	0.48	0.56	0.64	0.73	0.51	0.60	0.68	0.78	0.54	0.63	0.72	0.82	0.57	0.67	0.76	0.87	
		PI	2.94	2.95	2.95	2.96	3.12	3.13	3.13	3.13	3.31	3.31	3.32	3.32	3.51	3.51	3.52	3.52	
30		TC	12.51	12.52	12.54	12.56	13.26	13.28	13.29	13.31	14.05	14.07	14.09	14.11	14.90	14.92	14.93	14.95	
		S/T	0.49	0.58	0.66	0.75	0.52	0.61	0.70	0.80	0.55	0.65	0.74	0.84	0.59	0.69	0.78	0.89	
		PI	3.78	3.78	3.79	3.79	4.01	4.01	4.01	4.02	4.24	4.25	4.26	4.26	4.50	4.51	4.51	4.52	
35		TC	12.51	12.52	12.54	12.56	13.26	13.28	13.29	13.31	14.05	14.07	14.09	14.11	14.90	14.92	14.93	14.95	
		S/T	0.49	0.58	0.66	0.75	0.52	0.61	0.70	0.8									

1950	-15	TC	13.53	13.55	13.56	13.58	14.35	14.36	14.38	14.40	15.20	15.22	15.24	15.26	16.12	16.14	16.15	16.18
		S/T	0.49	0.57	0.65	0.74	0.51	0.60	0.69	0.78	0.55	0.64	0.73	0.83	0.58	0.68	0.77	0.88
		PI	3.20	3.21	3.21	3.21	3.39	3.40	3.40	3.41	3.60	3.60	3.61	3.61	3.81	3.82	3.82	3.83
	-10	TC	13.53	13.55	13.56	13.58	14.35	14.36	14.38	14.40	15.20	15.22	15.24	15.26	16.12	16.14	16.15	16.18
		S/T	0.49	0.57	0.65	0.74	0.52	0.61	0.69	0.78	0.55	0.64	0.73	0.83	0.58	0.68	0.77	0.88
		PI	3.09	3.09	3.09	3.10	3.27	3.28	3.28	3.29	3.47	3.47	3.48	3.48	3.68	3.68	3.69	3.69
	-5	TC	13.53	13.55	13.56	13.58	14.35	14.36	14.38	14.40	15.20	15.22	15.24	15.26	16.12	16.14	16.15	16.18
		S/T	0.49	0.58	0.65	0.75	0.52	0.61	0.69	0.79	0.55	0.65	0.74	0.84	0.58	0.69	0.78	0.89
		PI	2.95	2.95	2.95	2.96	3.12	3.13	3.13	3.14	3.31	3.32	3.32	3.32	3.51	3.51	3.52	3.52
	0	TC	13.53	13.55	13.56	13.58	14.35	14.36	14.38	14.40	15.20	15.22	15.24	15.26	16.12	16.14	16.15	16.18
		S/T	0.49	0.58	0.66	0.75	0.52	0.61	0.70	0.79	0.55	0.65	0.74	0.84	0.59	0.69	0.78	0.89
		PI	2.79	2.80	2.80	2.80	2.96	2.97	2.97	2.97	3.14	3.14	3.15	3.15	3.33	3.33	3.34	3.34
	5	TC	13.53	13.55	13.56	13.58	14.35	14.36	14.38	14.40	15.20	15.22	15.24	15.26	16.12	16.14	16.15	16.18
		S/T	0.49	0.58	0.66	0.75	0.52	0.61	0.70	0.80	0.56	0.65	0.74	0.84	0.59	0.69	0.78	0.89
		PI	2.56	2.56	2.56	2.57	2.71	2.71	2.72	2.72	2.87	2.88	2.88	2.88	3.05	3.05	3.05	3.06
	10	TC	13.53	13.55	13.56	13.58	14.35	14.36	14.38	14.40	15.20	15.22	15.24	15.26	16.12	16.14	16.15	16.18
		S/T	0.50	0.58	0.66	0.76	0.53	0.62	0.70	0.80	0.56	0.66	0.75	0.85	0.59	0.70	0.79	0.90
		PI	2.45	2.45	2.46	2.46	2.60	2.60	2.60	2.61	2.75	2.76	2.76	2.76	2.92	2.92	2.93	2.93
15	TC	13.53	13.55	13.56	13.58	14.35	14.36	14.38	14.40	15.20	15.22	15.24	15.26	16.12	16.14	16.15	16.18	
	S/T	0.50	0.59	0.67	0.76	0.53	0.62	0.71	0.81	0.56	0.66	0.75	0.86	0.60	0.70	0.80	0.91	
	PI	2.70	2.70	2.70	2.71	2.86	2.86	2.86	2.87	3.03	3.03	3.04	3.04	3.21	3.22	3.22	3.22	
20	TC	13.53	13.55	13.56	13.58	14.35	14.36	14.38	14.40	15.20	15.22	15.24	15.26	16.12	16.14	16.15	16.18	
	S/T	0.51	0.60	0.69	0.78	0.54	0.64	0.73	0.83	0.58	0.68	0.77	0.88	0.61	0.72	0.82	0.93	
	PI	2.94	2.94	2.95	2.95	3.12	3.12	3.12	3.13	3.30	3.31	3.31	3.32	3.50	3.51	3.51	3.52	
25	TC	13.53	13.55	13.56	13.58	14.35	14.36	14.38	14.40	15.20	15.22	15.24	15.26	16.12	16.14	16.15	16.18	
	S/T	0.52	0.61	0.69	0.79	0.55	0.65	0.74	0.84	0.59	0.69	0.78	0.89	0.62	0.73	0.83	0.94	
	PI	3.19	3.19	3.19	3.20	3.38	3.38	3.38	3.39	3.58	3.58	3.59	3.59	3.79	3.80	3.80	3.81	
30	TC	13.53	13.55	13.56	13.58	14.35	14.36	14.38	14.40	15.20	15.22	15.24	15.26	16.12	16.14	16.15	16.18	
	S/T	0.53	0.63	0.71	0.81	0.57	0.66	0.75	0.86	0.60	0.70	0.80	0.91	0.64	0.75	0.85	0.97	
	PI	4.09	4.09	4.10	4.10	4.33	4.34	4.34	4.35	4.59	4.60	4.60	4.61	4.87	4.87	4.88	4.89	
35	TC	13.53	13.55	13.56	13.58	14.35	14.36	14.38	14.40	15.20	15.22	15.24	15.26	16.12	16.14	16.15	16.18	
	S/T	0.53	0.63	0.71	0.81	0.57	0.66	0.75	0.86	0.60	0.70	0.80	0.91	0.64	0.75	0.85	0.97	
	PI	5.33	5.33	5.34	5.35	5.65	5.65	5.66	5.67	5.99	5.99	6.00	6.01	6.35	6.35	6.36	6.37	
40	TC	11.73	11.75	11.76	11.78	12.44	12.45	12.47	12.48	13.18	13.20	13.21	13.23	13.98	13.99	14.01	14.03	
	S/T	0.55	0.64	0.73	0.83	0.58	0.68	0.77	0.88	0.62	0.72	0.82	0.93	0.65	0.76	0.87	0.99	
	PI	4.73	4.74	4.74	4.75	5.02	5.02	5.03	5.04	5.32	5.32	5.33	5.34	5.64	5.64	5.65	5.66	
45	TC	9.07	9.09	9.10	9.11	9.62	9.63	9.64	9.66	10.20	10.21	10.22	10.23	10.81	10.82	10.83	10.85	
	S/T	0.57	0.67	0.77	0.87	0.61	0.71	0.81	0.92	0.65	0.76	0.86	0.98	0.68	0.80	0.91	1.00	
	PI	3.89	3.89	3.90	3.90	4.12	4.13	4.13	4.14	4.37	4.38	4.38	4.39	4.63	4.64	4.64	4.65	
50	TC	5.13	5.14	5.14	5.15	5.44	5.45	5.45	5.46	5.76	5.77	5.78	5.79	6.11	6.12	6.12	6.13	
	S/T	0.59	0.69	0.78	0.89	0.62	0.73	0.83	0.95	0.66	0.77	0.88	1.00	0.70	0.82	0.93	1.00	
	PI	2.67	2.67	2.68	2.68	2.83	2.84	2.84	2.84	3.00	3.01	3.01	3.01	3.18	3.19	3.19	3.19	

TC:Total Cooling Capacity (kW)

S/T:Sensible Cooling Capacity Ratio

PI:Power Input(kW)

Note: The table shows the case where the operation frequency of a compressor is fixed.

7.2 Heating

		48k(1Ph)								[SI_Unit]
INDOOR AIRFLOW (CMH)	OUTDOOR DB(°C)	HEATING PERFORMANCE AT INDOOR DRY BULB TEMPERATURE								
		TC:TOTAL CAPACITY IN KILOWATTS (KW)				PI:TOTAL POWER IN KILOWATTS (KW)				
		Indoor Conditions (DB °C)				Indoor Conditions (DB °C)				
		16.0	20.0	22.0	24.0	16.0	20.0	22.0	24.0	
1745	-20.0	11.26	11.16	11.09	11.04	4.81	4.98	4.87	4.89	
	-15.0	12.18	12.08	12.00	11.95	5.26	5.44	5.33	5.35	
	-10.0	13.01	12.90	12.81	12.76	5.61	5.81	5.69	5.70	
	-7.0	13.63	13.51	13.43	13.37	5.96	6.17	6.04	6.06	
	-5.6	13.63	13.51	13.43	13.37	5.79	5.83	5.85	5.88	
	-2.8	13.60	13.45	13.40	13.31	5.49	5.52	5.54	5.55	
	0.0	13.43	13.28	13.19	13.11	5.18	5.20	5.21	5.22	
	2.8	13.72	13.54	13.45	13.37	4.91	4.92	4.92	4.93	
	5.6	14.44	14.24	14.15	14.06	4.65	4.64	4.64	4.64	
	7.0	15.28	15.07	14.89	14.81	4.53	4.37	4.51	4.51	
	11.1	15.59	15.39	15.27	15.18	4.11	4.08	4.06	4.04	
	13.9	15.88	15.65	15.53	15.42	3.83	3.79	3.76	3.74	
	16.7	16.14	15.91	15.79	15.68	3.55	3.49	3.46	3.43	
18.0	16.29	16.03	15.91	15.79	3.41	3.34	3.31	3.28		
1910	-20.0	11.49	11.40	11.33	11.28	4.85	5.02	4.91	4.94	
	-15.0	12.44	12.33	12.26	12.21	5.30	5.49	5.37	5.40	
	-10.0	13.28	13.17	13.09	13.03	5.66	5.86	5.73	5.76	
	-7.0	13.91	13.80	13.71	13.65	6.01	6.23	6.09	6.12	
	-5.6	13.92	13.80	13.72	13.66	5.84	5.89	5.91	5.93	
	-2.8	13.89	13.74	13.69	13.60	5.54	5.57	5.58	5.59	
	0.0	13.72	13.54	13.48	13.40	5.23	5.25	5.26	5.27	
	2.8	14.00	13.83	13.74	13.63	4.96	4.97	4.97	4.97	
	5.6	14.73	14.56	14.44	14.35	4.69	4.69	4.68	4.68	
	7.0	15.57	15.39	15.21	15.13	4.58	4.41	4.55	4.55	
	11.1	15.94	15.71	15.59	15.50	4.15	4.11	4.10	4.08	
	13.9	16.20	15.97	15.85	15.74	3.87	3.82	3.80	3.77	
	16.7	16.49	16.23	16.11	16.00	3.58	3.52	3.49	3.46	
18.0	16.64	16.38	16.23	16.11	3.44	3.37	3.34	3.31		
2080	-20.0	11.62	11.52	11.45	11.40	4.90	5.07	4.96	4.98	
	-15.0	12.57	12.47	12.39	12.34	5.36	5.55	5.43	5.45	
	-10.0	13.42	13.31	13.23	13.17	5.71	5.92	5.79	5.82	
	-7.0	14.06	13.95	13.86	13.80	6.07	6.29	6.15	6.18	
	-5.6	14.06	13.95	13.86	13.80	5.90	5.94	5.97	5.99	
	-2.8	14.03	13.89	13.80	13.74	5.58	5.62	5.63	5.65	
	0.0	13.86	13.69	13.60	13.51	5.28	5.30	5.31	5.32	
	2.8	14.12	13.95	13.86	13.77	5.01	5.01	5.02	5.02	
	5.6	14.87	14.67	14.58	14.50	4.74	4.73	4.73	4.72	
	7.0	15.75	15.53	15.36	15.27	4.62	4.45	4.60	4.59	
	11.1	16.09	15.85	15.74	15.65	4.18	4.15	4.13	4.11	
	13.9	16.35	16.11	16.00	15.88	3.89	3.85	3.83	3.80	
	16.7	16.64	16.38	16.26	16.14	3.61	3.55	3.52	3.49	
18.0	16.78	16.52	16.38	16.26	3.47	3.40	3.37	3.33		

Note: The table shows the case where the operation frequency of a compressor is fixed.

		48k(3Ph)				[SI_Unit]			
INDOOR AIRFLOW (CMH)	HEATING PERFORMANCE AT INDOOR DRY BULB TEMPERATURE								
	OUTDOOR DB(°C)	TC:TOTAL CAPACITY IN KILOWATTS (KW)				PI:TOTAL POWER IN KILOWATTS (KW)			
		Indoor Conditions (DB °C)				Indoor Conditions (DB °C)			
		16.0	20.0	22.0	24.0	16.0	20.0	22.0	24.0
1745	-20.0	10.38	10.26	10.22	10.17	4.60	4.76	4.67	4.70
	-15.0	11.23	11.11	11.06	11.00	5.03	5.20	5.11	5.14
	-10.0	12.00	11.86	11.81	11.75	5.37	5.55	5.45	5.49
	-7.0	12.57	12.42	12.37	12.31	5.70	5.90	5.79	5.83
	-5.6	12.74	12.60	12.54	12.48	5.55	5.61	5.64	5.67
	-2.8	12.89	12.74	12.66	12.60	5.30	5.34	5.37	5.39
	0.0	12.89	12.74	12.66	12.57	5.05	5.08	5.10	5.12
	2.8	13.35	13.18	13.09	13.01	4.83	4.86	4.87	4.88
	5.6	14.25	14.08	13.99	13.88	4.62	4.63	4.64	4.65
	7.0	15.26	15.07	14.81	14.72	4.52	4.41	4.53	4.54
	11.1	15.79	15.56	15.48	15.36	4.17	4.16	4.16	4.15
	13.9	16.23	16.03	15.91	15.79	3.94	3.93	3.92	3.91
	16.7	16.69	16.46	16.35	16.23	3.71	3.68	3.66	3.65
18.0	16.93	16.67	16.55	16.43	3.60	3.56	3.54	3.52	
1910	-20.0	10.59	10.47	10.43	10.36	4.64	4.80	4.72	4.74
	-15.0	11.46	11.34	11.28	11.21	5.07	5.25	5.16	5.19
	-10.0	12.24	12.10	12.05	11.97	5.41	5.60	5.50	5.53
	-7.0	12.82	12.68	12.62	12.54	5.75	5.95	5.85	5.88
	-5.6	13.01	12.86	12.80	12.71	5.61	5.67	5.69	5.72
	-2.8	13.15	13.01	12.95	12.86	5.35	5.39	5.42	5.44
	0.0	13.15	13.01	12.92	12.83	5.10	5.13	5.15	5.17
	2.8	13.64	13.47	13.35	13.27	4.88	4.90	4.92	4.93
	5.6	14.57	14.37	14.28	14.20	4.66	4.68	4.68	4.69
	7.0	15.61	15.39	15.13	15.04	4.56	4.45	4.57	4.58
	11.1	16.11	15.91	15.79	15.68	4.21	4.20	4.20	4.19
	13.9	16.58	16.35	16.23	16.11	3.98	3.96	3.95	3.94
	16.7	17.04	16.81	16.69	16.55	3.74	3.71	3.69	3.68
18.0	17.28	17.01	16.90	16.78	3.63	3.59	3.57	3.55	
2080	-20.0	10.69	10.58	10.53	10.48	4.69	4.85	4.77	4.79
	-15.0	11.57	11.44	11.39	11.34	5.13	5.31	5.21	5.24
	-10.0	12.36	12.22	12.17	12.11	5.47	5.66	5.56	5.59
	-7.0	12.95	12.80	12.74	12.69	5.81	6.02	5.91	5.94
	-5.6	13.12	12.98	12.92	12.86	5.67	5.73	5.76	5.78
	-2.8	13.27	13.12	13.06	12.98	5.40	5.45	5.48	5.50
	0.0	13.30	13.12	13.03	12.95	5.15	5.19	5.20	5.22
	2.8	13.76	13.59	13.50	13.41	4.93	4.96	4.97	4.98
	5.6	14.69	14.51	14.40	14.31	4.71	4.73	4.74	4.74
	7.0	15.72	15.53	15.27	15.18	4.61	4.50	4.62	4.63
	11.1	16.26	16.06	15.94	15.82	4.26	4.25	4.24	4.24
	13.9	16.75	16.52	16.40	16.29	4.03	4.01	4.00	3.99
	16.7	17.22	16.96	16.84	16.72	3.78	3.75	3.74	3.72
18.0	17.45	17.19	17.07	16.93	3.67	3.63	3.61	3.60	

Note: The table shows the case where the operation frequency of a compressor is fixed.

55k								[SI_Unit]	
INDOOR AIRFLOW (CMH)	HEATING PERFORMANCE AT INDOOR DRY BULB TEMPERATURE								
	OUTDOOR DB(°C)	TC:TOTAL CAPACITY IN KILOWATTS (KW)				PI:TOTAL POWER IN KILOWATTS (KW)			
		Indoor Conditions (DB °C)				Indoor Conditions (DB °C)			
		16.0	20.0	22.0	24.0	16.0	20.0	22.0	24.0
1600	-20.0	11.92	11.80	11.73	11.66	5.41	5.59	5.51	5.55
	-15.0	12.90	12.77	12.70	12.62	5.91	6.11	6.03	6.07
	-10.0	13.78	13.64	13.56	13.48	6.31	6.52	6.43	6.48
	-7.0	14.43	14.29	14.20	14.12	6.70	6.93	6.83	6.88
	-5.6	14.69	14.55	14.46	14.38	6.55	6.64	6.68	6.72
	-2.8	14.93	14.75	14.67	14.58	6.30	6.38	6.40	6.44
	0.0	14.99	14.78	14.69	14.61	6.05	6.11	6.14	6.17
	2.8	15.57	15.36	15.25	15.16	5.84	5.90	5.92	5.95
	5.6	16.67	16.44	16.35	16.23	5.64	5.68	5.70	5.73
	7.0	17.90	17.65	17.33	17.21	5.55	5.48	5.60	5.62
	11.1	18.52	18.29	18.14	18.03	5.21	5.23	5.24	5.25
	13.9	19.10	18.84	18.72	18.58	4.99	5.00	5.01	5.01
	16.7	19.68	19.42	19.27	19.13	4.76	4.76	4.76	4.76
18.0	19.97	19.68	19.54	19.39	4.65	4.64	4.64	4.64	
1750	-20.0	12.17	12.05	11.98	11.93	5.45	5.64	5.57	5.61
	-15.0	13.17	13.04	12.97	12.91	5.97	6.17	6.09	6.13
	-10.0	14.06	13.93	13.84	13.79	6.36	6.59	6.49	6.54
	-7.0	14.73	14.59	14.50	14.45	6.76	7.00	6.90	6.95
	-5.6	14.99	14.84	14.75	14.69	6.62	6.70	6.74	6.79
	-2.8	15.22	15.04	14.96	14.90	6.37	6.43	6.47	6.51
	0.0	15.28	15.10	14.99	14.90	6.11	6.17	6.20	6.24
	2.8	15.86	15.65	15.57	15.45	5.90	5.96	5.99	6.01
	5.6	16.99	16.79	16.67	16.55	5.70	5.74	5.77	5.79
	7.0	18.21	18.00	17.68	17.56	5.61	5.54	5.67	5.68
	11.1	18.90	18.64	18.52	18.37	5.27	5.29	5.30	5.31
	13.9	19.48	19.22	19.07	18.93	5.05	5.06	5.06	5.07
	16.7	20.06	19.80	19.65	19.51	4.82	4.82	4.82	4.82
18.0	20.35	20.06	19.91	19.77	4.71	4.70	4.70	4.69	
1950	-20.0	12.28	12.16	12.09	12.02	5.51	5.70	5.62	5.66
	-15.0	13.29	13.16	13.09	13.01	6.03	6.24	6.15	6.19
	-10.0	14.19	14.05	13.97	13.89	6.43	6.65	6.56	6.61
	-7.0	14.87	14.72	14.64	14.55	6.83	7.07	6.97	7.02
	-5.6	15.13	14.99	14.90	14.81	6.68	6.77	6.81	6.86
	-2.8	15.36	15.19	15.10	15.01	6.42	6.50	6.54	6.57
	0.0	15.42	15.25	15.13	15.04	6.17	6.24	6.27	6.30
	2.8	16.03	15.80	15.71	15.60	5.97	6.02	6.05	6.08
	5.6	17.16	16.93	16.81	16.73	5.76	5.81	5.83	5.85
	7.0	18.42	18.17	17.85	17.74	5.67	5.60	5.73	5.75
	11.1	19.07	18.81	18.69	18.55	5.33	5.35	5.36	5.37
	13.9	19.68	19.39	19.27	19.13	5.10	5.11	5.12	5.12
	16.7	20.26	19.97	19.83	19.68	4.87	4.87	4.87	4.87
18.0	20.55	20.26	20.12	19.97	4.76	4.75	4.75	4.75	

Note: The table shows the case where the operation frequency of a compressor is fixed.

8. Capacity Correction Factor for Height Difference

Capacity (Btu/h)	48k		Pipe Length (m)							
			5	15	25	35	50	65	75	
Cooling										
Height difference H (m)	Indoor Upper than Outdoor	30	/	/	/	0.880	0.838	0.796	0.768	
		20	/	/	0.918	0.889	0.846	0.804	0.775	
		10	/	0.956	0.927	0.898	0.855	0.812	0.783	
		5	0.995	0.966	0.937	0.907	0.864	0.820	0.791	
		0	1.000	0.971	0.941	0.912	0.868	0.824	0.795	
	Outdoor Upper than Indoor	-5	1.000	0.971	0.941	0.912	0.868	0.824	0.795	
		-10	/	0.971	0.941	0.912	0.868	0.824	0.795	
		-20	/	/	0.941	0.912	0.868	0.824	0.795	
		-30	/	/	/	0.912	0.868	0.824	0.795	
	Heating									
Height difference H (m)	Indoor Upper than Outdoor	30	/	/	/	0.956	0.933	0.911	0.896	
		20	/	/	0.970	0.956	0.933	0.911	0.896	
		10	/	0.985	0.970	0.956	0.933	0.911	0.896	
		5	1.000	0.985	0.970	0.956	0.933	0.911	0.896	
		0	1.000	0.985	0.970	0.956	0.933	0.911	0.896	
	Outdoor Upper than Indoor	-5	0.992	0.977	0.963	0.948	0.926	0.904	0.889	
		-10	/	0.969	0.955	0.940	0.918	0.896	0.882	
		-20	/	/	0.947	0.933	0.911	0.889	0.875	
		-30	/	/	/	0.925	0.904	0.882	0.868	

Capacity (Btu/h)		55k		Pipe Length (m)						
		Cooling		5	15	25	35	50	65	75
Height difference H (m)	Indoor Upper than Outdoor	30					0.866	0.816	0.767	0.734
		20				0.908	0.875	0.825	0.774	0.741
		10			0.951	0.917	0.884	0.833	0.782	0.749
		5	0.995	0.961	0.927	0.893	0.841	0.790	0.756	
		0	1.000	0.966	0.931	0.897	0.846	0.794	0.760	
	Outdoor Upper than Indoor	-5	1.000	0.966	0.931	0.897	0.846	0.794	0.760	
		-10		0.966	0.931	0.897	0.846	0.794	0.760	
		-20			0.931	0.897	0.846	0.794	0.760	
		-30				0.897	0.846	0.794	0.760	
			Heating		5	15	25	35	50	65
Height difference H (m)	Indoor Upper than Outdoor	30					0.953	0.929	0.905	0.889
		20				0.968	0.953	0.929	0.905	0.889
		10			0.984	0.968	0.953	0.929	0.905	0.889
		5	1.000	0.984	0.968	0.953	0.929	0.905	0.889	
		0	1.000	0.984	0.968	0.953	0.929	0.905	0.889	
	Outdoor Upper than Indoor	-5	0.992	0.976	0.961	0.945	0.921	0.898	0.882	
		-10		0.968	0.953	0.937	0.914	0.891	0.875	
		-20			0.945	0.930	0.907	0.883	0.868	
-30					0.922	0.899	0.876	0.861		

9. Noise Criterion Curves

Indoor Unit

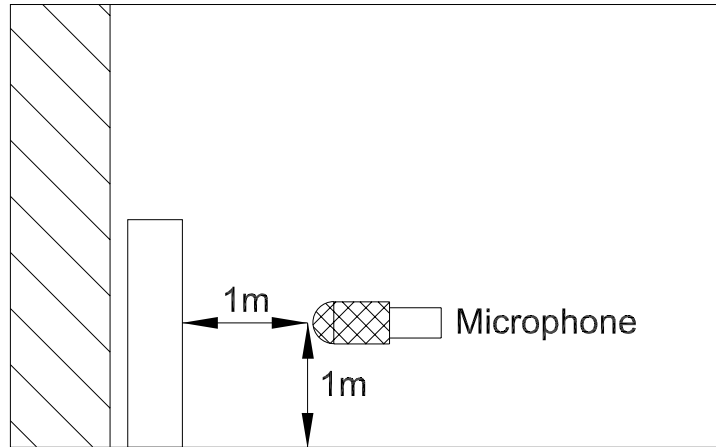

Notes:

- Sound measured at 1m away from the noisiest location of the unit.
- Data is valid at free field condition
- Data is valid at nominal operation condition
- Reference acoustic pressure $OdB = 20\mu Pa$
- Sound level will vary depending on a range of factors such as the construction -(acoustic absorption coefficient) of particular room in which the equipment is installed.
- The operating conditions are assumed to be standard.

MFM-48HRFN8-QRD0W

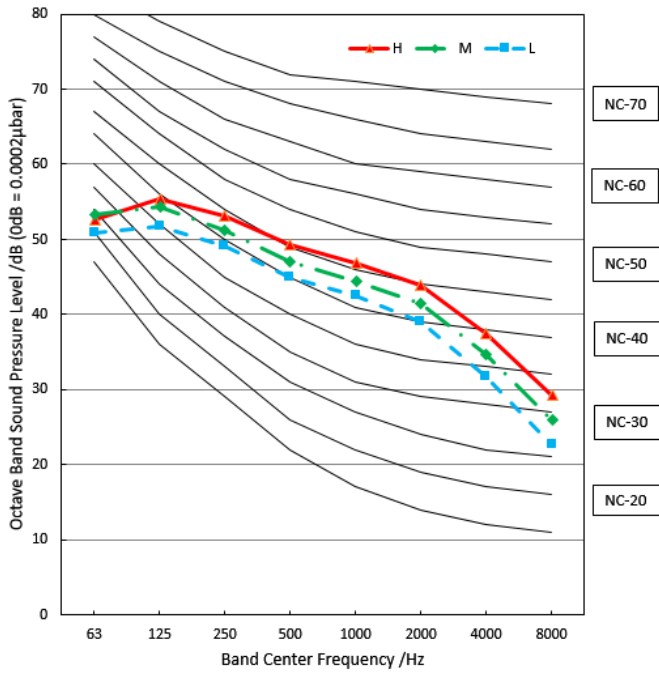

MFM-55HRFN8-QRD0W

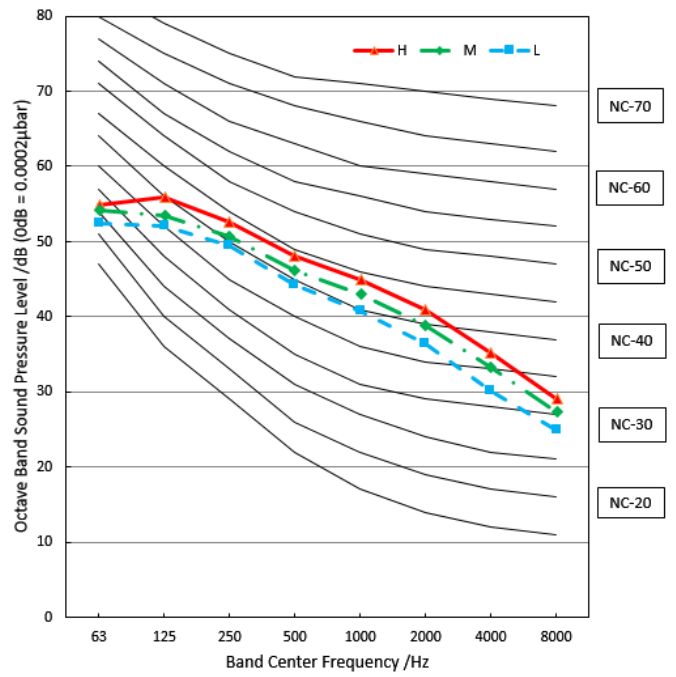

Outdoor Unit

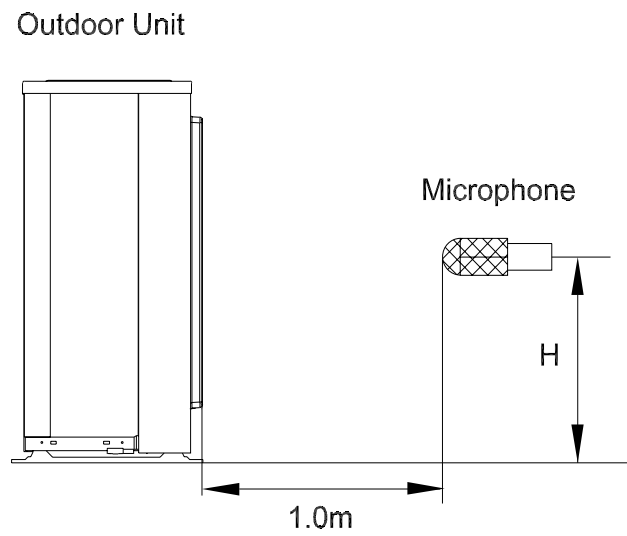

Note: $H = 0.5 \times$ height of outdoor unit

Notes:

- Sound measured at 1.0m away from the center of the unit.
- Data is valid at free field condition
- Data is valid at nominal operation condition
- Reference acoustic pressure $OdB=20\mu Pa$
- Sound level will vary depending on arrangement of factors such as the construction (acoustic absorption coefficient) of particular room in which the equipment is installed.
- The operating conditions are assumed to be standard.

MOX630U-48HFN8-QRD0W(GA)

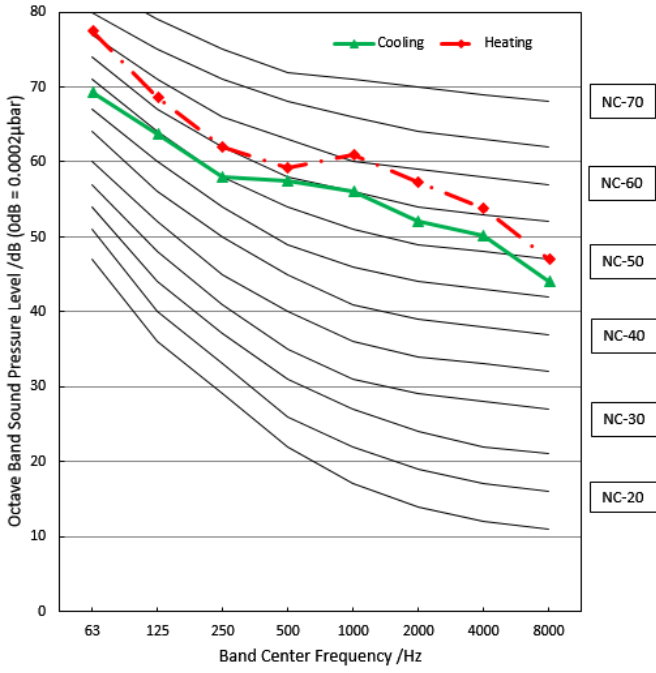

MOX630U-48HFN8-RRD0W(GA)

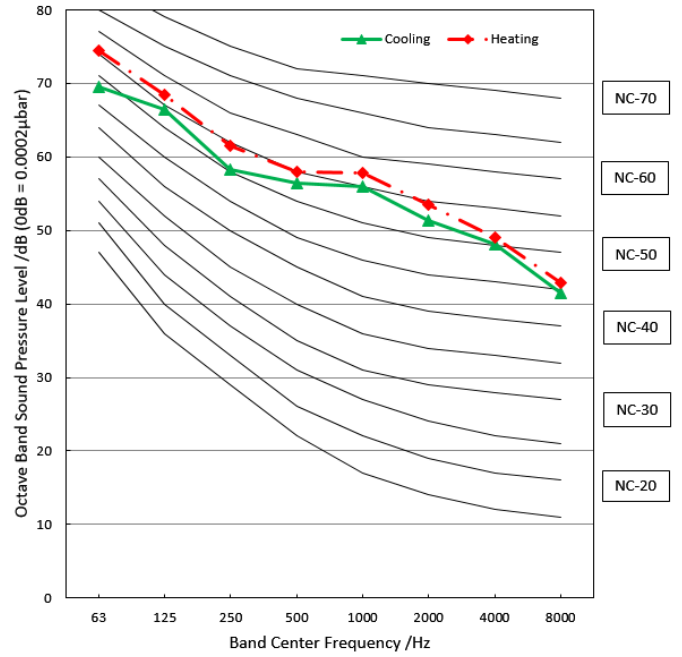

MOX630U-55HFN8-RRD0W(GA)

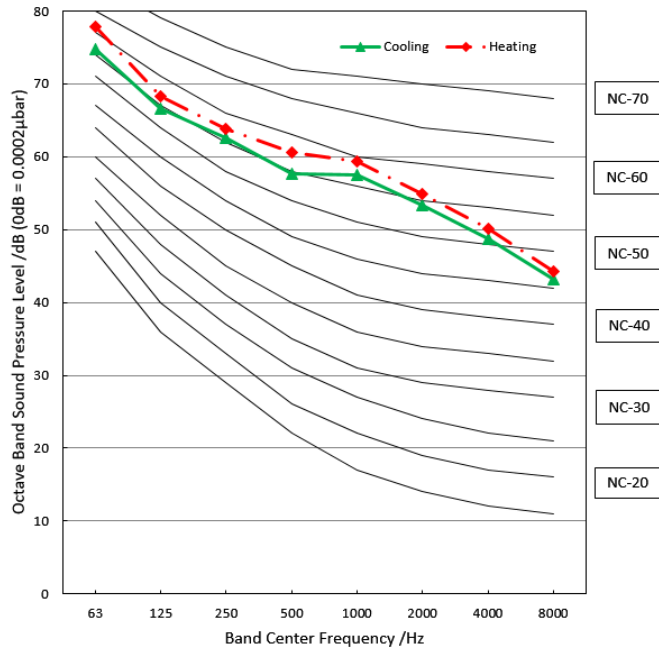

10. Electrical Characteristics

Model		48k	48k/55k
Power	Phase	1- Phase	3- Phase
	Frequency and Voltage	220-240V~,50Hz	380-415V~,50Hz
Circuit Breaker/ Fuse (A)		50/40	32/25
Outdoor Unit Power Wiring (mm ²)		3x6.0	5x2.5
Indoor/Outdoor Connecting Wiring (mm ²)	Strong Electric Signal	4x1.5	4x1.5
	Weak Electric Signal		

Product Features

Contents

1. Operation Modes and Functions	32
1.1 Abbreviation	32
1.2 Safety Features	32
1.3 Display Function.....	32
1.4 Fan Mode	32
1.5 Cooling Mode.....	32
1.6 Heating Mode(Heat pump units).....	33
1.7 Auto-mode	34
1.8 Drying mode.....	34
1.9 Sleep function.....	34
1.10 8°C Heating(Optional).....	35
1.11 Self Clean(Optional)	35
1.12 Follow Me(Optional)	35
1.13 Silence(Optional).....	35
1.14 Auto-Restart Function	35
2. Remoted Controller Functions	36
2.1 Infrared Wireless Remote Controller	36

1. Operation Modes and Functions

1.1 Abbreviation

Unit element abbreviations

Abbreviation	Element
T1	Indoor room temperature
T2	Coil temperature of evaporator
T3	Coil temperature of condenser
T4	Outdoor ambient temperature
TS	Set temperature
TP	Compressor discharge temperature

In this manual, such as CDIFTEMP, HDIFTEMP2, TCE1, TCE2...etc., they are well-setting parameter of EEPROM.

1.2 Safety Features

Compressor three-minute delay at restart

Compressor functions are delayed for up to one minute upon the first startup of the unit, and are delayed for up to three minutes upon subsequent unit restarts.

Automatic shutoff based on discharge temperature

If the compressor discharge temperature exceeds a certain level for a period of time, the compressor ceases operation.

Inverter module protection

The inverter module has an automatic shutoff mechanism based on the unit's current, voltage, and temperature. If automatic shutoff is initiated, the corresponding error code is displayed on the indoor unit and the unit ceases operation.

Indoor fan delayed operation

- When the unit starts, the louver is automatically activated and the indoor fan will operate after a period of setting time.
- If the unit is in heating mode, the indoor fan is regulated by the anti-cold wind function.

Sensor redundancy and automatic shutoff

- If one temperature sensor malfunctions, the air conditioner continues operation and displays the corresponding error code, allowing for emergency use.
- When more than one temperature sensor is malfunctioning, the air conditioner ceases operation.

Refrigerant leakage detection(

This function is active only when cooling mode is selected. It will detect if the compressor is being damaged by refrigerant leakage or by compressor overload. This is measured using the coil temperature of evaporator T2 when the compressor is in operation.

Automatic shutoff based on fan speed

When indoor fan speed registers 300RPM for 50s, the indoor fan ceases operation and restarts 30s later, if protection happened 3 times when fan motor restarts continuously, the unit ceases operation and the corresponding error code is displayed on the indoor unit.

Low pressure check function

The low pressure switch should be always closed. If it is open, the air conditioner ceases operation until the fault is cleared.

1.3 Display Function

Unit display functions

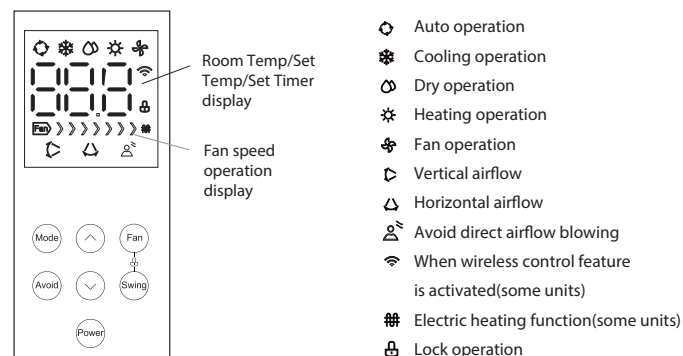

1.4 Fan Mode

When fan mode is activated:

- The outdoor fan and compressor are stopped.
- Temperature control is disabled and no temperature setting is displayed.
- The indoor fan speed can be set to high, low, or auto.
- The louver operations are identical to those in cooling mode.
- Auto fan: In fan-only mode, AC operates the same as auto fan in cooling mode with the temperature set at 24°C.

1.5 Cooling Mode

1.5.1 Compressor Control

Reach the configured temperature:

- 1) When the compressor runs continuously for less than

120 minutes.

- If the following conditions are satisfied, the compressor ceases operation.
 - While calculated frequency(f_b) is less than minimum limit frequency(F_{minC}).
 - While protective time is more than or equal to ten minutes.
 - While T_1 is lower than or equal to $(T_{sc}-CDIFTEMP-0.5^{\circ}C)$

Note: CDIFTEMP is EEPROM setting parameter. It is $2^{\circ}C$ usually.

2) When the compressor runs continuously for more than 120 minutes.

- If the following conditions are satisfied, the compressor ceases operation.
 - When calculated frequency(f_b) is less than minimum limit frequency(F_{minC}).
 - When protective time is more than or equal to ten minutes.
 - When T_1 is lower than or equal to $(T_{sc}-CDIFTEMP)$.

Note: CDIFTEMP is EEPROM setting parameter. It is $2^{\circ}C$ usually.

3) If one of the following conditions is satisfied, not judge protective time.

- Compressor running frequency is more than test frequency.
- When compressor running frequency is equal to test frequency, T_4 is higher than $15^{\circ}C$ or T_4 sensor fault
- Change setting temperature.
- Turbo function on/off
- Various frequency limit shutdown occurs.

1.5.2 Indoor Fan Control

- In cooling mode, the indoor fan operates continuously. The fan speed can be set to high, (medium), low, or auto.
- Auto fan in cooling mode:

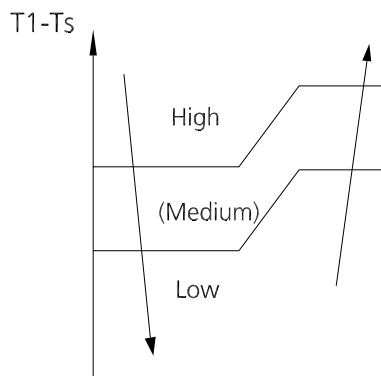

1.5.3 Outdoor Fan Control

- The outdoor unit will be run at different fan speed according to T_4 and compressor frequency.
- For different outdoor units, the fan speeds are different.

1.5.4 Condenser Temperature Protection

When condenser temperature is more than setting value, the compressor ceases operation..

1.5.5 Evaporator Temperature Protection

When evaporator temperature drops below a configured value, the compressor and outdoor fan cease operation.

1.6 Heating Mode(Heat pump units)

1.6.1 Compressor Control

1) Reach the configured temperature

- If the following conditions are satisfied, the compressor ceases operation.
 - While calculated frequency(f_b) is less than minimum limit frequency(F_{minH}).
 - When protective time is more than or equal to ten minutes.
 - When T_1 is higher than or equal to $T_{sc}+HDIFTEMP2$.

Note: HDIFTEMP2 is EEPROM setting parameter. It is $2^{\circ}C$ usually.

- If one of the following conditions is satisfied, not judge protective time.
 - Compressor running frequency is more than test frequency.
 - When compressor running frequency is equal to test frequency, T_4 is higher than $15^{\circ}C$ or T_4 sensor fault.
 - Change setting temperature.
 - Turbo function on/off.

2) When the current is higher than the predefined safe value, surge protection is activated, causing the compressor to cease operation.

1.6.2 Indoor Fan Control:

- When the compressor is on, the indoor fan speed can be set to high, (medium) ,low, or auto. And the anti-cold wind function has the priority.
- Anti-cold air function
 - The indoor fan is controlled by the indoor unit coil temperature T_2 .

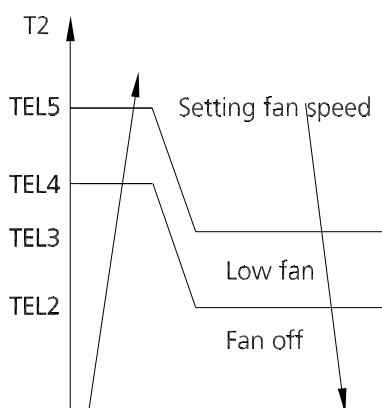

- Auto fan action in heating mode:

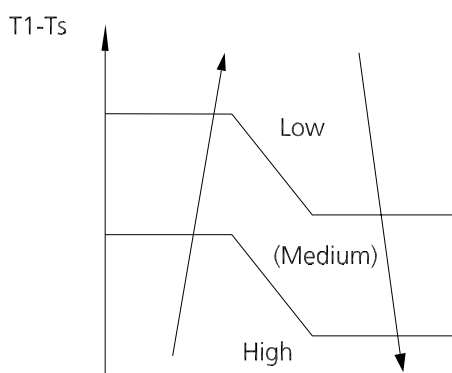

1.6.3 Outdoor Fan Control:

- The outdoor unit will be run at different fan speed according to T4 and compressor frequency.
- For different outdoor units, the fan speeds are different.

1.6.4 Defrosting mode

- The unit enters defrosting mode according to the temperature value of T3 and T4 as well as the compressor running time.
- In defrosting mode, the compressor continues to run, the indoor and outdoor motor will cease operation, the defrost light of the indoor unit will turn on, and the “df” symbol is displayed.
- If any one of the following conditions is satisfied, defrosting ends and the machine switches to normal heating mode:
 - T3 rises above TCDE1.
 - T3 maintained above TCDE2 for 80 seconds.
 - Unit runs for 15 minutes consecutively in defrosting mode.
- If T4 is lower than or equal to -22°C and compressor running time is more than TIMING_DEFROST_TIME, if any one of the following conditions is satisfied, defrosting ends and the machine switches to normal heating mode:

- Unit runs for 10 minutes consecutively in defrosting mode.
- T3 rises above 10°C.

1.6.5 Evaporator Temperature Protection

When the evaporator temperature exceeds a preset protection value, the compressor ceases operation.

1.7 Auto-mode

- This mode can be selected with the remote controller and the setting temperature can be changed between 16°C~30°C.
- In auto mode, the machine selects cooling, heating, or fan-only mode on the basis of T1, Ts and T4.

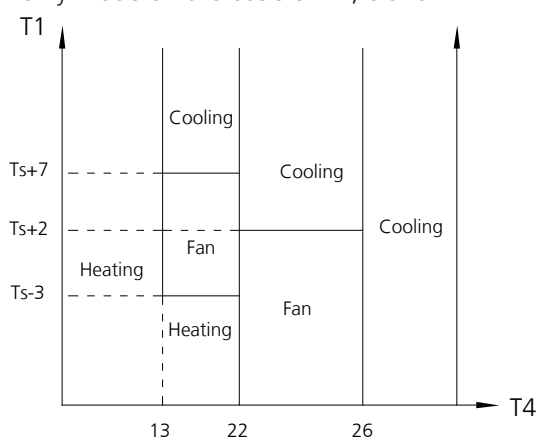

- If the setting temperature is modified, the machine selects a new running function.

1.8 Drying mode

- AC operates the same as auto fan in cooling mode.
- When $T1 < 17^{\circ}\text{C}$, the fan speed is lower than 30%, the unit will operate at 30%.
- Low Room Temperature Protection
 - If the room temperature is lower than 10°C, the compressor ceases operations and does not resume until room temperature exceeds 12°C.
- All protections are active and the same as that in cooling mode.

1.9 Sleep function

- The sleep function is available in cooling, heating, or auto mode.
- The operational process for sleep mode is as follows:
 - When cooling, the temperature rises 1°C(2°F) (to not higher than 30°C(86°F)) every hour. After 2 hours, the temperature stops rising and the indoor fan is fixed at low speed.
 - When heating, the temperature decreases 1°C(2°F)

(to not lower than 17°C(62.6°F)) every hour. After 2 hours, the temperature stops decreasing and the indoor fan is fixed at low speed. Anti-cold wind function takes priority.

- The unit exits sleep operation when it receives the following signals:
 - Switch off
 - Turbo
 - Silence
 - Self-clean
 - Changes in:
 - mode
 - fan speed

1.10 8°C Heating(Optional)

In heating mode, the temperature can be set to as low as 8°C, preventing the indoor area from freezing if unoccupied during severe cold weather.

1.11 Self Clean(Optional)

- If you press “Self Clean” when the unit is in cooling or drying mode:
 - The indoor unit will run in low fan mode for a certain time, then ceases operation.
- Self Clean keeps the indoor unit dry and prevents mold growth.
- When match with multi outdoor unit, this function is disabled.

1.12 Follow Me(Optional)

- If you press “Follow Me” on the remote, the indoor unit will beep. This indicates the follow me function is active.
- Once active, the remote control will send a signal every 3 minutes, with no beeps. The unit automatically sets the temperature according to the measurements from the remote control.
- The unit will only change modes if the information from the remote control makes it necessary, not from the unit’s temperature setting.
- If the unit does not receive a signal for 7 minutes or you press “Follow Me,” the function turns off. The unit regulates temperature based on its own sensor and settings.

1.13 Silence(Optional)

- Press “Silence” on the remote control to enable the

SILENCE function. While this function is active, the compressor frequency is maintained at a lower level than F3. The indoor unit will run at faint breeze, which reduces noise to the lowest possible level.

- When match with multi outdoor unit, this function is disabled.

1.14 Auto-Restart Function

- The indoor unit has an auto-restart module that allows the unit to restart automatically. The module automatically stores the current settings and, in the case of a sudden power failure, will restore those setting automatically after power returns.

2. Remoted Controller Functions

2.1 Infrared Wireless Remote Controller

2.1.1. RG51B/E(Standard)

Remote Controller Specifications

Model	RG51B/E
Rated Voltage	3.0V (Dry batteries R03/LR03×2)
Reaching Distance	8m((when using 3.0 voltage, it Gets 11m))
Environment Temperature Range	-5°C~60°C (23°F~140°F)

Buttons and Functions

TEMP ▼
Decreases temperate in 1°C (1°F) increments. Min. temperatu re is 17°C (62°F).

ON/OFF
Turns the unit on or off.

MODE
Scrolls through operation modes as follows:

AUTO → COOL → DRY → [HEAT] → FAN

NOTE: Please do not select HEAT mode if the machine you purchased is cooling only type. Heat mode is not supported by the cooling only appliance.

SWING
Starts and stops the horizontal louver movement. Hold down for 2 seconds to initiate vertical louver auto swing feature(some units) .

SLEEP
Saves energy during sleeping hours .

DIRECT
Use to set airflow direction.

SHORT CUT
Sets and activates your favorite pre-settings

CLEAN
Used to start/stop the Self Clean or Active Clean function(Model dependent).

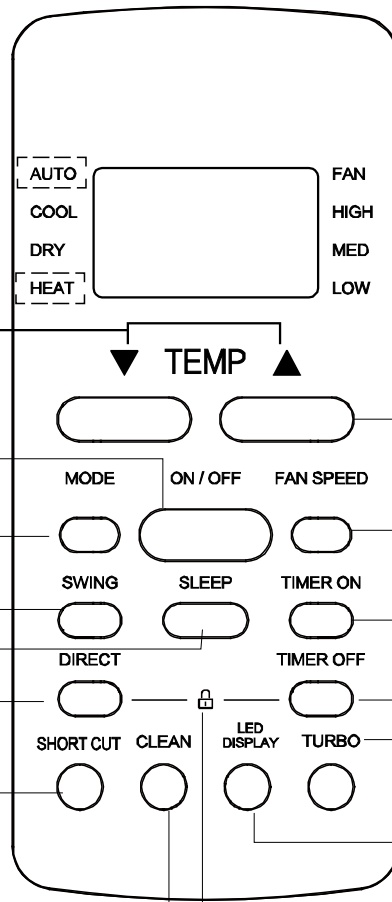

TEMP ▲
Increases temperate in 1°C (1°F) increments. Max. temperatu re is 30°C (86°F).

FAN SPEED
Selects fan speeds in the following order:
AUTO → LOW → MED → HIGH

TIMER ON
Sets timer to tu rn unit on

TIMER OFF
Sets timer to tu rn unit off

TURBO
Enables unit to reach preset temperatu re in shortest possible time.

LED DISPLAY
Turns indoor unit's LED display and air conditioner buzzer on and off (model dependent), which create a comfortable and quiet environment.





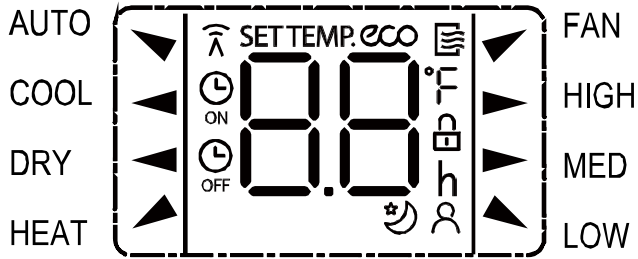



LOCK
Press together DIREC T & TIMER OFF buttons simultaneously for 5 seconds to lock the keyboard. Press together the two buttons for 2 seconds to unlock the keyboard.

Remote LCD Screen Indicators



Mode display

AUTO ▼ COOL ◀ DRY ◀
HEAT ▲ ▼ FAN

-
-  Displayed when data transmitted.
 -  Displayed when remote controller is ON.
 -  Displayed when TIMER ON time is set
 -  Displayed when TIMER OFF time is set
 -  Shows set temperature or room temperature, or time under TIMER setting
 -  Displayed when ECO feature is activated (some unit)
 -  Indicated all the current settings are locked
 -  Displayed when Follow Me feature is activated (some units)
 -  Displayed when SLEEP feature is activated

Fan speed indication

-
- ▶ HIGH High speed
 - ▶ MED Medium speed
 - ▲ LOW Low speed
 - NO display Auto fan speed
-

Note:

All indicators shown in the figure are for the purpose of clear presentation. But during the actual operation, only the relative function signs are shown on the display window.

How To Use The Basic Functions

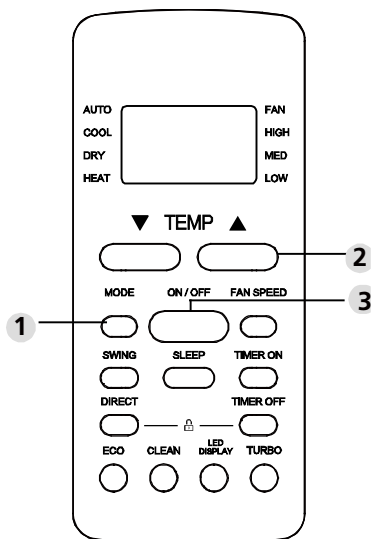

COOL Operation

1. Press the MODE button to select COOL mode.
2. Set your desired temperature using the Temp ▲ or Temp ▼ button.
3. Press the FAN button to select the fan speed in a range of Au-100%, in conjunction with Temp ▲ or Temp ▼ button.
4. Press the ON/OFF button to start the unit.

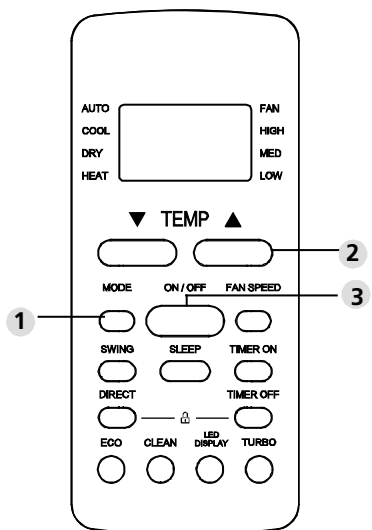

Setting Temperature

The operating temperature range for units is 16-30°C/60-86°F. You can increase or decrease the set temperature in 0.5°C/1°F increments.

AUTO Operation

In AUTO mode, the unit will automatically select the COOL, FAN, HEAT or DRY mode based on the set temperature.

1. Press the MODE button to select Auto mode.
2. Set your desired temperature using the Temp ▲ or Temp ▼ button.
3. Press the ON/OFF button to start the unit.

NOTE: FAN SPEED can't be set in Auto mode.

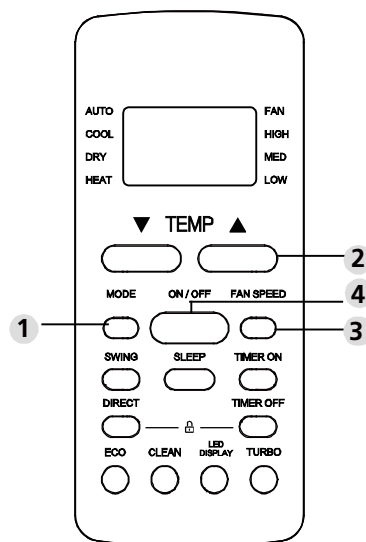

DRY Operation(dehumidifying)

1. Press the MODE button to select DRY mode.
2. Set your desired temperature using the Temp ▲ or Temp ▼ button.
3. Press the ON/OFF button to start the unit.

NOTE: FAN SPEED can't be changed in DRY mode.

FAN Operation

1. Press the MODE button to select FAN mode.
2. Press the FAN button to select the fan speed in a range of Au-100%, in conjunction with Temp ▲ or Temp ▼ button.
3. Press the ON/OFF button to start the unit.

NOTE: You can't set temperature in FAN mode. As a result, your remote control sLCD screen will not display temperature.

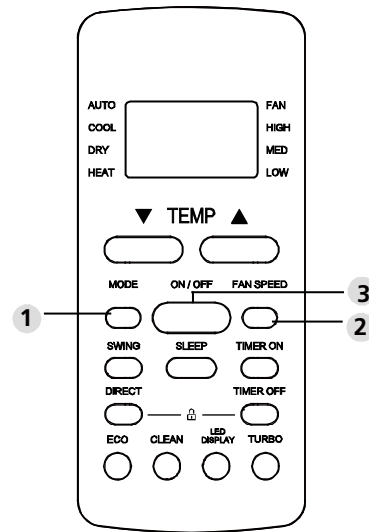
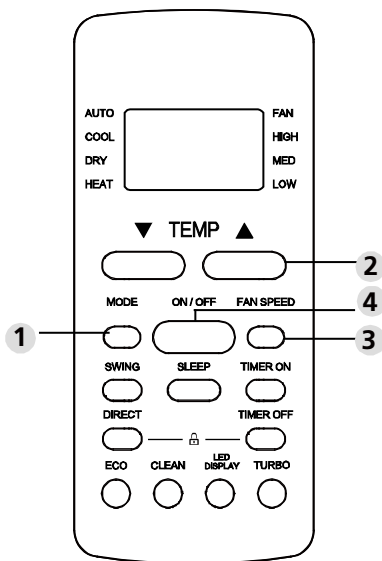

HEAT Operation

1. Press the MODE button to select HEAT mode.
2. Set your desired temperature using the Temp ▲ or Temp ▼ button.
3. Press the FAN button to select the fan speed in a range of Au-100%, in conjunction with Temp ▲ or Temp ▼ button.
4. Press the ON/OFF button to start the unit.

NOTE: As outdoor temperature drops, the performance of your unit's HEAT function may be affected. In such instances, we recommend using this air conditioner in conjunction with other heating appliance.

How To Use The Advanced Functions

Swing function

Press Swing button

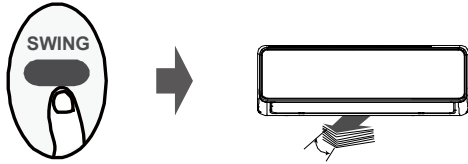

The horizontal louver will swing up and down automatically when pressing Swing button.

Press again to make it stop.

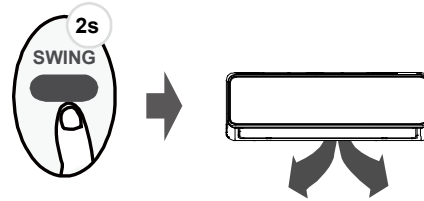

Keep pressing this button more than 2 seconds, the vertical louver swing function is activated. (Model dependent)

Airflow direction

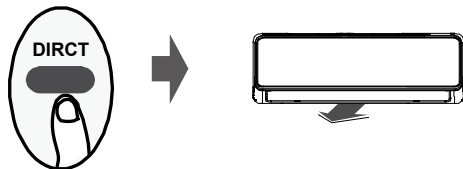

Each time you press the button, it will adjust the louver by 6°. Press the button until the direction you prefer is reached.

LED DISPLAY

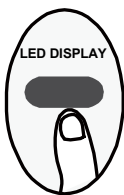

Press LED button

Press this button to turn on and turn off the display on the indoor unit.

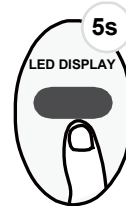

Press this button more than 5 seconds (some units)

Keep pressing this button more than 5 seconds, the indoor unit will display the actual room temperature. Press more than 5 seconds again will revert back to setting temperature.

SHORTCUT function

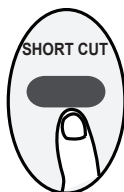

Used to restore the current settings or resume previous settings.

Push this button when remote controller is on, the system will automatically revert back to the previous settings including operating mode, setting temperature, fan speed level and sleep feature (if activated).

If pushing more than 2 seconds, the system will automatically restore the current operation settings including operating mode, setting temperature, fan speed level and sleep feature (if activated).

SLEEP function



The SLEEP function is used to decrease energy use while you sleep (and don't need the same temperature settings to stay comfortable). This function can only be activated via remote control.

The sleep function is not available in Fan or Dry mode.

Silence function



Keep pressing Fan button for more than 2 seconds to activate/disable Silence function(some units).















Due to low frequency operation of compressor, it may result in insufficient cooling and heating capacity. Press ON/OFF, Mode, Sleep, Turbo or Clean button while operating will cancel silence function.

Installation

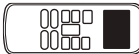
Contents

Accessories	43
1. Installation Overview	44
2. Location selection	45
3. Indoor Unit Installation	46
4. Outdoor unit installation	47
5. Drainpipe installation	48
6. Refrigerant Pipe Installation	49
7. Vacuum Drying and Leakage Checking	50
8. Additional Refrigerant Charge	51
9. Engineering of Electrical Wiring	52
10. Test Operation	52

Accessories

	Name	Shape	Quantity
Indoor unit installation	Self-tapping screw (Used to fix the cord clamp of indoor unit after wire connection)		3
	Flat washers		2
	Bushing-sleeve cover		1
Refrigeration Fittings	Soundproof/insulation sheath (some models)		2
Drainpipe Fittings	Drain hose(some models)		1
	Band (some models)		2
	Drain joint (some models)		1
	Seal ring (some models)		1
Remote controller & Its Frame	Remote controller		1
	Fixing screw for remote controller holder ST2.9 x 10(optional)		2
	Remote controller holder(optional)		1
	Dry battery AAA		2
Installation Accessory (some models)	Connection cables		1
	Putty		1
	Rodent-proof mesh		1
	Flat washers		2
Others	Manual		2~3
	Refrigerant Pipe (optional)		1

1. Installation Overview

Installation Order

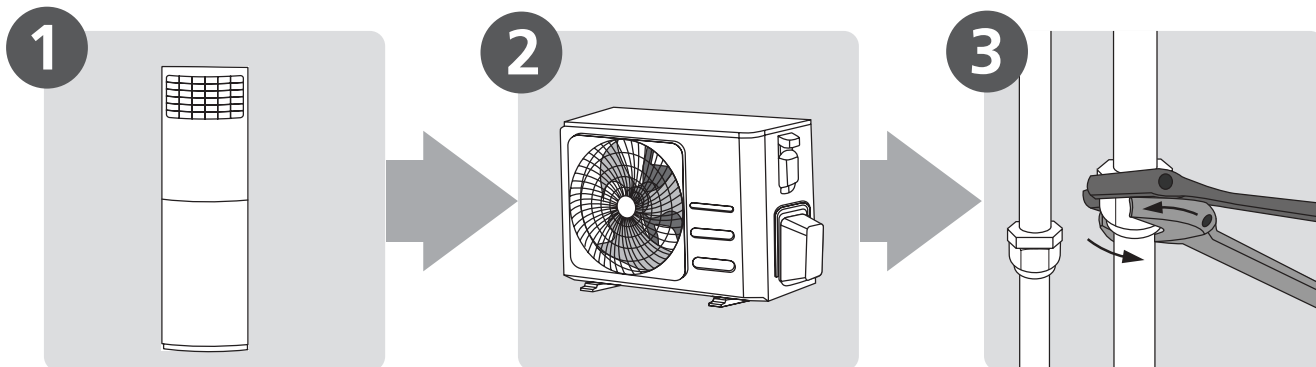

1 Install the indoor unit

2 Install the outdoor unit

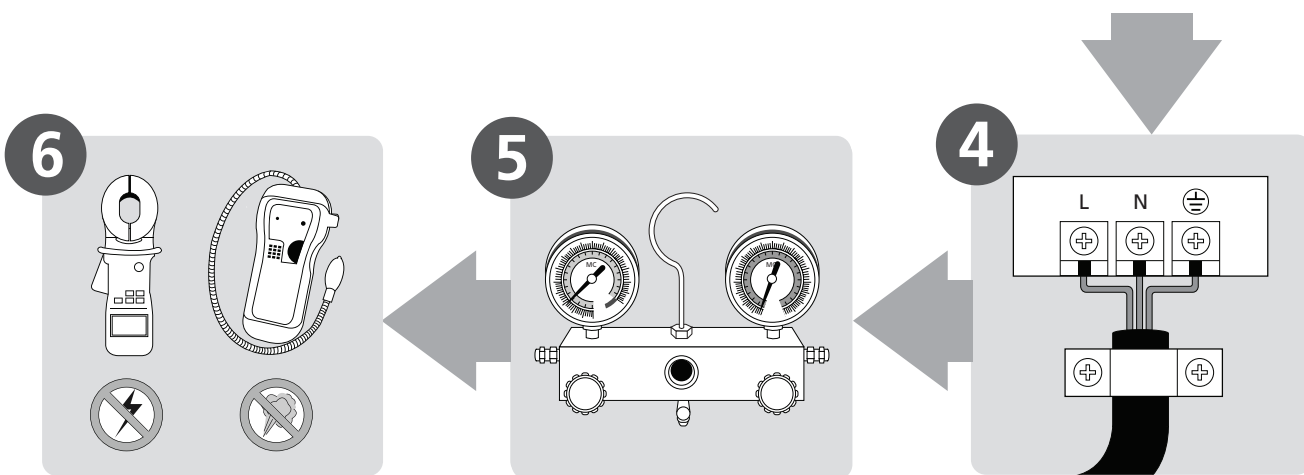

6 Perform a test run

5 Evacuate the refrigeration system

4 Connect the wires

2. Location selection

2.1 Unit location selection can refer to installation manual.

2.2 DO NOT install the unit in the following locations:

- Where oil drilling or fracking is taking place.
- Coastal areas with high salt content in the air.
- Areas with caustic gases in the air, such as near hot springs.
- Areas with power fluctuations, such as factories.
- Enclosed spaces, such as cabinets.
- Areas with strong electromagnetic waves.
- Areas that store flammable materials or gas.
- Rooms with high humidity, such as bathrooms or laundry rooms.
- If possible, DO NOT install the unit where it is exposed to direct sunlight.

2.3 The minimum distance between the outdoor unit and walls described in the installation guide does not apply to airtight rooms. Be sure to keep the unit unobstructed in at least two of the three directions (M, N, P)

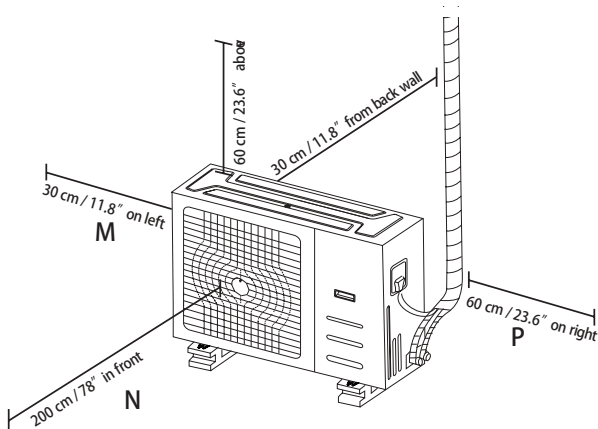

2.4 Rows of series installation

The relations between H, A and L are as follows.

	L	A
$L \leq H$	$L \leq 1/2H$	25 cm / 9.8" or more
	$1/2H < L \leq H$	30 cm / 11.8" or more
$L > H$	Can not be installed	

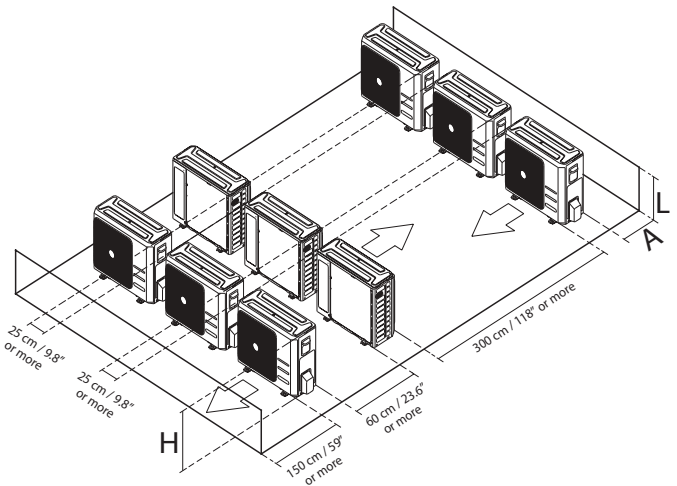

DO NOT install the rows of series like following figure.

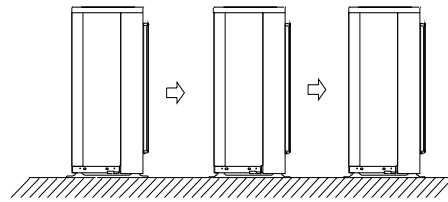

2.5. If the unit is exposed to heavy wind:

- Install unit so that air outlet fan is at a 90° angle to the direction of the wind. If needed, build a barrier in front of the unit to protect it from extremely heavy winds.

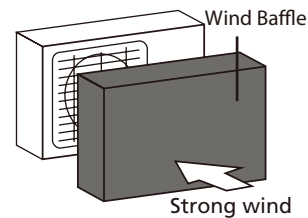
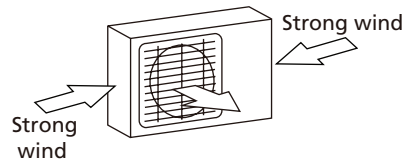

2.6 If the unit is frequently exposed to heavy rain or snow:

Build a shelter above the unit to protect it from the rain or snow. Be careful not to obstruct air flow around the unit.

2.7 If the unit is frequently exposed to salty air (seaside):

Use outdoor unit that is specially designed to resist corrosion.

3. Indoor Unit Installation

3.1 Service space for indoor unit

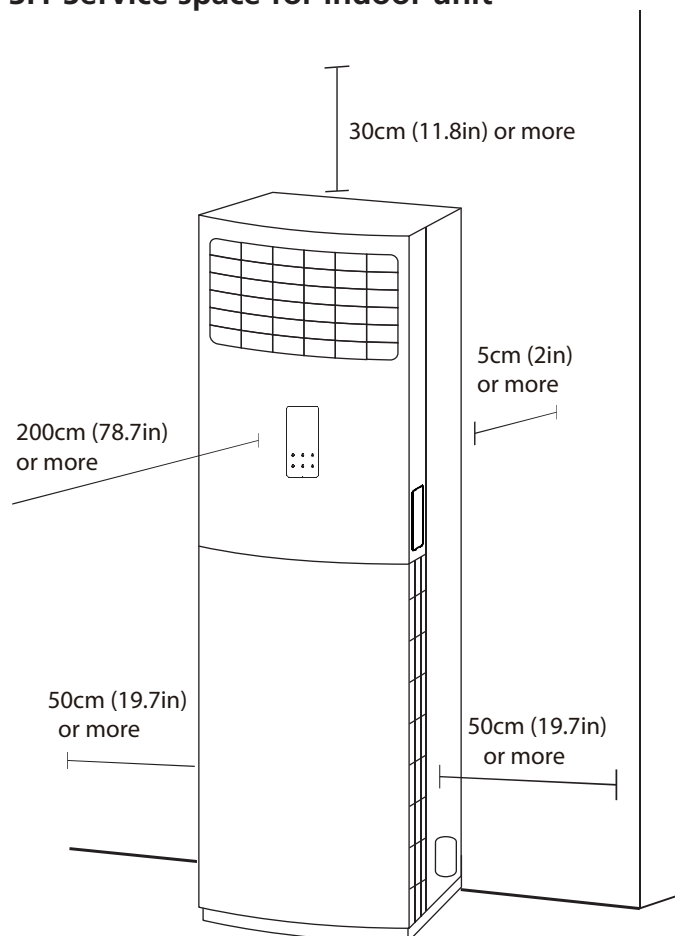

3.2 Install Indoor Unit

1. Unfastening the operation panel and detaching the filter

- Open the packaging and take out the indoor unit. Remove the protective tape and any components.
- Open the screw cover on the upper part of the lower side inlet grille and remove the retaining screw.
- Please take off the air-inlet grid before connecting the pipes/wires.
 - First remove the screws cover, then remove the screws on the air-inlet grid, then take off the grid.

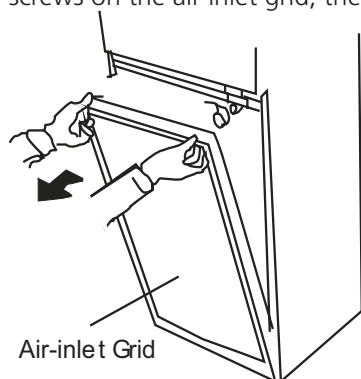

- Remove all of the accessories placed inside the bottom cavity of the indoor unit.
 - Check that all of the accessories match those found on the "Accessories" as shown on the previous page.
- ##### 2. Remove the fasteners from the roller (only found on selected models)
- Check to see whether the roller on the indoor unit has any fasteners holding it in place and tear off the notice sticker.
 - Remove the fasteners from the roller according to the directions on the sticker.
- ##### 3. Fastening the indoor unit (to prevent it from falling down)
- Measure the position of the holes for installation.
 - Insert the M8 bolts into the unit while it is on the floor (the amount of bolts used depends on the number of holes on the unit's chassis).
 - Lift up the indoor unit so that the installation holes cover the bolts, then fasten the nuts onto the bolts and tighten them.

⚠ CAUTION:

If further support is needed to prevent the unit from falling down, a protective wedge can be installed. The installation procedure for this wedge is as follows:

- Take out the protective wedge and measure the correct size.
 - Use the self-tapping screws to fasten the protective wedge to the top cover of the indoor unit.
 - Fasten the other end of the wedge tightly to the wall using the self-tapping screws.
- ##### 4. Installing the rodent-proof mesh
- Remove the metal rodent-proof mesh from the piping found on the unit by gently tapping on it.
 - Use a knife to cut a small hole by following the markings on the ratproof board.
 - Insert the ratproof board into the unit and hold it in place tightly.

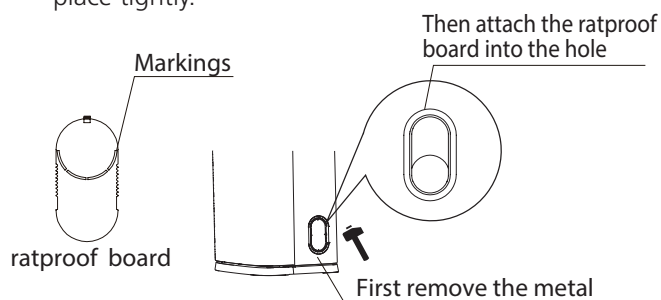

4. Outdoor unit installation

4.1 Service space for outdoor unit

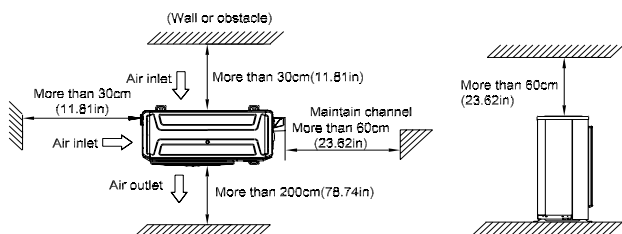

4.2 Bolt pitch

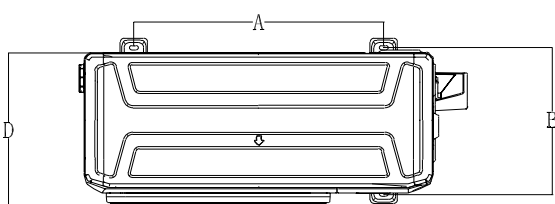

Model	A	B	D
MOX630U-48HFN8-QRD0W(GA)			
MOX630U-48HFN8-RRD0W(GA)	615	397	375
MOX630U-55HFN8-RRD0W(GA)			

4.3 Install Outdoor Unit

Fix the outdoor unit with anchor bolts(M10)

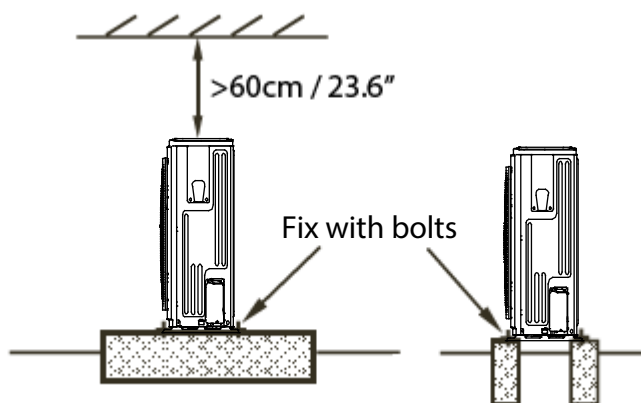

Caution

Since the gravity center of the unit is not at its physical center, so please be careful when lifting it with a sling.

Never hold the inlet of the outdoor unit to prevent it from deforming.

Do not touch the fan with hands or other objects.

Do not lean it more than 45°, and do not lay it sidelong.

Make concrete foundation according to the specifications

of the outdoor units.

Fasten the feet of this unit with bolts firmly to prevent it from collapsing in case of earthquake or strong wind.

4.4 Install drain joint

Heat pump units require a drain joint. Before bolting the outdoor unit in place, you must install the drain joint at the bottom of the unit. Note that there are two different types of drain joints depending on the type of outdoor unit.

- **If the drain joint comes with a rubber seal (see Fig. A), do the following:**

1. Fit the rubber seal on the end of the drain joint that will connect to the outdoor unit.
2. Insert the drain joint into the hole in the base pan of the unit.
3. Rotate the drain joint 90° until it clicks in place facing the front of the unit.
4. Connect a drain hose extension (not included) to the drain joint to redirect water from the unit during heating mode.

- **If the drain joint doesn't come with a rubber seal (see Fig. B), do the following:**

1. Insert the drain joint into the hole in the base pan of the unit. The drain joint will click in place.
2. Connect a drain hose extension (not included) to the drain joint to redirect water from the unit during heating mode.

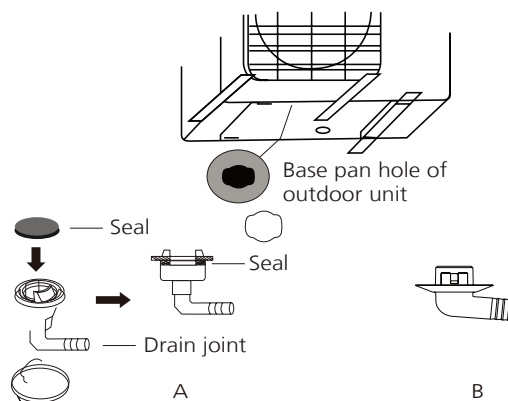

5. Drainpipe installation

The drainpipe is used to drain water from the unit. Improper installation may cause unit and property damage.

⚠ CAUTION:

- Insulate all piping to prevent condensation, which could lead to water damage.
- If the drainpipe is bent or installed incorrectly, water may leak and cause a malfunction of the water-level switch.
- In HEAT mode, the outdoor unit will discharge water. Ensure that the drain hose is placed in an appropriate area to avoid water damage and slippage due to frozen drain water.
- DO NOT pull the drainpipe forcefully as this could cause it to disconnect.

NOTE ON PURCHASING PIPES:

This installation requires a polyethylene tube (outside diameter = 3.7-3.9cm, inside diameter = 3.2cm), which can be obtained at your local hardware store or from your dealer.

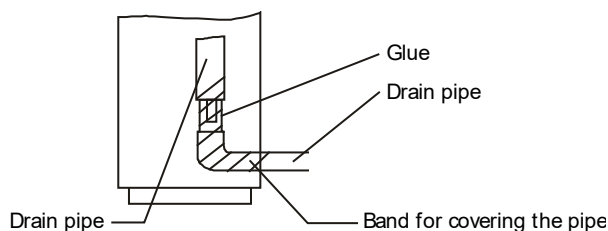

1. Make sure the drain pipe is connected to the outdoor side downward.
2. The hard polyvinyl chloride(PVC)plastic pipe (external diameter 26 mm) sold in the market is suitable for the attached soft drain pipe.
3. Please connect the Soft Drain Pipe with the Drain Pipe, then fix it with band; if you have to connect the Drain Pipe indoors, to avoid condensing caused by air intake, you must cover the pipe with heat-insulation material (polyethylene with Specific Gravity of 0.03, at least 9 mm in thickness), and use Glue Band to fix it.
4. After the Drain Pipe has been connected, please check if the water drains out of the pipe efficiently and has no leakage.
5. Refrigerant Pipe and Drain Pipe should be heat-insulated to avoid condensing and water-dropping later on.
6. Using a 65-mm (2.5") core drill, drill a hole in the wall. Make sure that the hole is drilled at a slight downward angle, so that the outdoor end of the hole is lower than the indoor end by about 1 cm (0.4"). This will ensure

proper water drainage. Place the protective wall cuff in the hole. This protects the edges of the hole and will help seal it when you finish the installation process.

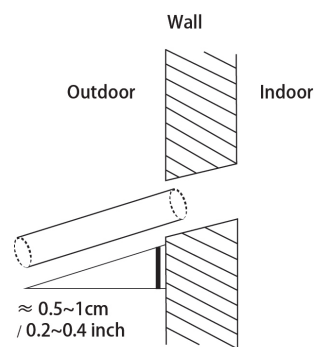

NOTE: When drilling the wall hole, make sure to avoid wires, plumbing, and other sensitive components.

7. Pass the drain hose through the wall hole. Make sure the water drains to a safe location where it will not cause water damage or a slipping hazard.

NOTE: The drainpipe outlet should be at least 5cm (1.9") above the ground. If it touches the ground, the unit may become blocked and malfunction. If you discharge the water directly into a sewer, make sure that the drain has a U or S pipe to catch odors that might otherwise come back into the house.

6. Refrigerant Pipe Installation

6.1 Maximum length and drop height

Ensure that the length of the refrigerant pipe, the number of bends, and the drop height between the indoor and outdoor units meets the requirements shown in the following table.

Capacity(kBtu/h)	Max. Length (m/ft)	Max. Elevation (m/ft)
48/55	75/246	30/98.4

Caution:

1. The capacity test is based on the standard length and the maximum permissible length is based on the system reliability.

2. Oil traps

-If oil flows back into the outdoor unit's compressor, this might cause liquid compression or deterioration of oil return. Oil traps in the rising gas piping can prevent this.

-An oil trap should be installed every 6m(20ft) of vertical suction line riser (<36000Btu/h unit).

-An oil trap should be installed every 10m(32.8ft) of vertical suction line riser (≥36000Btu/h unit).

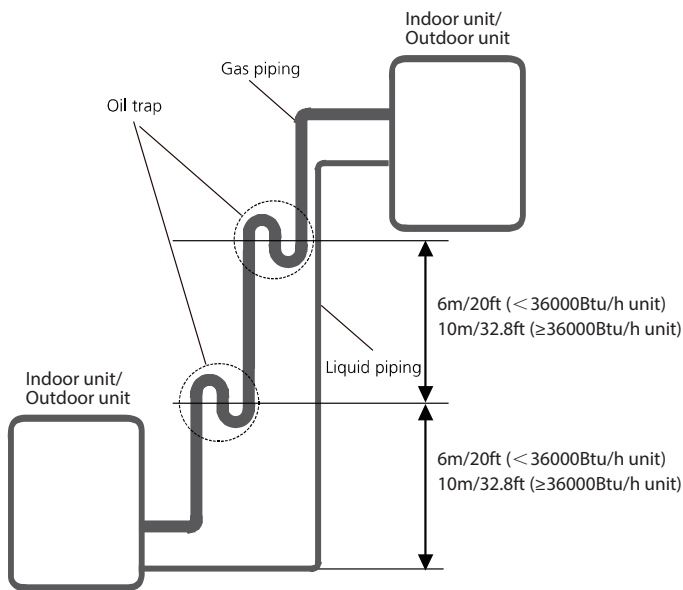

6.2 The procedure of connecting pipes

1. Choose the pipe size according to the specification table.
2. Confirm the cross way of the pipes.
3. Measure the necessary pipe length.
4. Cut the selected pipe with pipe cutter
 - Make the section flat and smooth.

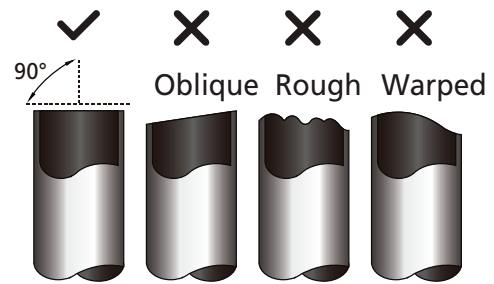

5. Insulate the copper pipe

- Before test operation, the joint parts should not be heat insulated.

6. Flare the pipe

- Insert a flare nut into the pipe before flaring the pipe
- According to the following table to flare the pipe.

Pipe diameter (inch(mm))	Flare dimension A (mm/inch)		Flare shape
	Min	Max	
1/4" (6.35)	8.4/0.33	8.7/0.34	
3/8" (9.52)	13.2/0.52	13.5/0.53	
1/2" (12.7)	16.2/0.64	16.5/0.65	
5/8" (15.9)	19.2/0.76	19.7/0.78	
3/4" (19)	23.2/0.91	23.7/0.93	
7/8" (22)	26.4/1.04	26.9/1.06	

- After flared the pipe, the opening part must be seal by end cover or adhesive tape to avoid duct or exogenous impurity come into the pipe.

7. Drill holes if the pipes need to pass the wall.

8. According to the field condition to bend the pipes so that it can pass the wall smoothly.

9. Bind and wrap the wire together with the insulated pipe if necessary.

10. Set the wall conduit

11. Set the supporter for the pipe.

12. Locate the pipe and fix it by supporter

- For horizontal refrigerant pipe, the distance between supporters should not be exceed 1m.
- For vertical refrigerant pipe, the distance between supporters should not be exceed 1.5m.

13. Connect the pipe to indoor unit and outdoor unit by using two spanners.

- Be sure to use two spanners and proper torque to fasten the nut, too large torque will damage the bellmouthing, and too small torque may cause leakage. Refer the following table for different pipe connection.

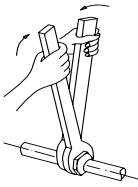
Pipe Diameter	Torque	Sketch map
	N.m(lb.ft)	
1/4" (6.35)	18~20 (13.3~14.8)	
3/8" (9.52)	32~39 (23.6~28.8)	
1/2" (12.7)	49~59 (36.1~43.5)	
5/8" (15.9)	57~71 (42~52.4)	
3/4" (19)	67~101 (49.4~74.5)	
7/8" (22)	85~110 (62.7~81.1)	

7. Vacuum Drying and Leakage Checking

7.1 Purpose of vacuum drying

- Eliminating moisture in system to prevent the phenomena of ice-blockage and copper oxidation. Ice-blockage shall cause abnormal operation of system, while copper oxide shall damage compressor.
- Eliminating the non-condensable gas (air) in system to prevent the components oxidizing, pressure fluctuation and bad heat exchange during the operation of system.

7.2 Selection of vacuum pump

- The ultimate vacuum degree of vacuum pump shall be -756mmHg or above.
- Precision of vacuum pump shall reach 0.02mmHg or above.

7.3 Operation procedure for vacuum drying

Due to different construction environment, two kinds of vacuum drying ways could be chosen, namely ordinary vacuum drying and special vacuum drying.

7.3.1 Ordinary vacuum drying

1. When conduct first vacuum drying, connect pressure gauge to the infusing mouth of gas pipe and liquid pipe, and keep vacuum pump running for 1hour (vacuum degree of vacuum pump shall be reached -755mmHg).
2. If the vacuum degree of vacuum pump could not reach -755mmHg after 1 hour of drying, it indicates that there is moisture or leakage in pipeline system and need to go on with drying for half an hour.
3. If the vacuum degree of vacuum pump still could not reach -755mmHg after 1.5 hours of drying, check whether there is leakage source.
4. Leakage test: After the vacuum degree reaches -755mmHg, stop vacuum drying and keep the pressure for 1 hour. If the indicator of vacuum gauge does not go up, it is qualified. If going up, it indicates that there is moisture or leak source.

7.3.2 Special vacuum drying

The special vacuum drying method shall be adopted when:

1. Finding moisture during flushing refrigerant pipe.
2. Conducting construction on rainy day, because rain water might penetrated into pipeline.
3. Construction period is long, and rain water might penetrated into pipeline.

4. Rain water might penetrate into pipeline during construction.

Procedures of special vacuum drying are as follows:

1. Vacuum drying for 1 hour.
2. Vacuum damage, filling nitrogen to reach 0.5Kgf/cm² .

Because nitrogen is dry gas, vacuum damage could achieve the effect of vacuum drying, but this method could not achieve drying thoroughly when there is too much moisture. Therefore, special attention shall be drawn to prevent the entering of water and the formation of condensate water.

3. Vacuum drying again for half an hour.

If the pressure reached -755mmHg, start to pressure leakage test. If it cannot reached the value, repeat vacuum damage and vacuum drying again for 1 hour.

4. Leakage test: After the vacuum degree reaches -755mmHg, stop vacuum drying and keep the pressure for 1 hour. If the indicator of vacuum gauge does not go up, it is qualified. If going up, it indicates that there is moisture or leak source.

8. Additional Refrigerant Charge

- After the vacuum drying process is carried out, the additional refrigerant charge process need to be performed.
- The outdoor unit is factory charged with refrigerant. The additional refrigerant charge volume is decided by the diameter and length of the liquid pipe between indoor and outdoor unit. Refer the following formula to calculate the charge volume.

Diameter of liquid pipe (mm)	Formula
6.35	$V=12g/m \times (L-5)$
9.52	$V=24g/m \times (L-5)$

V: Additional refrigerant charge volume (g).

L : The length of the liquid pipe (m).

Note:

- Refrigerant may only be charged after performed the vacuum drying process.
- Always use gloves and glasses to protect your hands and eyes during the charge work.
- Use electronic scale or fluid infusion apparatus to weight refrigerant to be recharged. Be sure to avoid extra refrigerant charged, it may cause liquid hammer of the compressor or protections.
- Use supplementing flexible pipe to connect refrigerant cylinder, pressure gauge and outdoor unit. And The refrigerant should be charged in liquid state. Before recharging, The air in the flexible pipe and manifold gauge should be exhausted.
- After finished refrigerant recharge process, check whether there is refrigerant leakage at the connection joint part.(Using gas leakage detector or soap water to detect).

9. Engineering of Electrical Wiring

1. Highlights of electrical wiring installation

- All field wiring construction should be finished by qualified electrician.
- Air conditioning equipment should be grounded according to the local electrical regulations.
- Current leakage protection switch should be installed.
- Do not connect the power wire to the terminal of signal wire.
- When power wire is parallel with signal wire, put wires to their own wire tube and remain at least 300mm gap.
- According to table in indoor part named "the specification of the power" to choose the wiring, make sure the selected wiring not small than the date showing in the table.
- Select different colors for different wire according to relevant regulations.
- Do not use metal wire tube at the place with acid or alkali corrosion, adopt plastic wire tube to replace it.
- There must be not wire connect joint in the wire tube If joint is a must, set a connection box at the place.
- The wiring with different voltage should not be in one wire tube.
- Ensure that the color of the wires of outdoor and the terminal No. are same as those of indoor unit respectively.

Table: Minimum Cross-Sectional Area able of Power and Signal Cables

Rated Current of Appliance (A)	Nominal Cross-Sectional Area(mm ²)
≤ 6	0.75
6 - 10	1
10 - 16	1.5
16 - 25	2.5
25 - 32	4
32 - 45	6

10. Test Operation

1. The test operation must be carried out after the entire installation has been completed.

2. Please confirm the following points before the test operation.

- The indoor unit and outdoor unit are installed properly.
- Piping and wiring are properly connected.
- Ensure that there are no obstacles near the inlet and outlet of the unit that might cause poor performance or product malfunction.
- The refrigeration system does not leak.
- The drainage system is unimpeded and draining to a safe location.
- The heating insulation is properly installed.
- The grounding wires are properly connected
- The length of the piping and the added refrigerant stow capacity have been recorded.
- The power voltage is the correct voltage for the air conditioner.

CAUTION: Failure to perform the test run may result in unit damage, property damage or personal injury.

3. Test Run Instructions

1. Open both the liquid and gas stop valves.
2. Turn on the main power switch and allow the unit to warm up.
3. Set the air conditioner to COOL mode, and check the following points.

Indoor unit

- Ensure the remote control and its buttons work properly.
- Ensure the louvers move properly and can be changed using the remote control.
- Double check to see if the room temperature is being registered correctly.
- Ensure the indicators on the remote control and the display panel on the indoor unit work properly.
- Ensure the manual buttons on the indoor unit works properly.
- Check to see that the drainage system is unimpeded and draining smoothly.
- Ensure there is no vibration or abnormal noise during operation.

Outdoor unit

- Check to see if the refrigeration system is leaking.
- Make sure there is no vibration or abnormal noise during operation.
- Ensure the wind, noise, and water generated by the

unit do not disturb your neighbors or pose a safety hazard.

3. Drainage Test

- a. Ensure the drainpipe flows smoothly. New buildings should perform this test before finishing the ceiling.
- b. Remove the test cover. Add 2000ml of water to the tank through the attached tube.
- c. Turn on the main power switch and run the air conditioner in COOL mode.
- d. Listen to the sound of the drain pump to see if it makes any unusual noises.
- e. Check to see that the water is discharged. It may take up to one minute before the unit begins to drain depending on the drainpipe.
- f. Make sure that there are no leaks in any of the piping.
- g. Stop the air conditioner. Turn off the main power switch and reinstall the test cover.