

SOLAR COLLECTOR

EN INSTALLER MANUAL

[EN]

romstal

ACCESSORIES

For a complete list of accessories and details of their compatibility, refer to the Catalogue.

*Dear heating engineer,
We would like to congratulate you on having recommended our Solar collector unit: a modern product that's capable of ensuring a high degree of reliability, efficiency, quality and safety. This booklet provides the information necessary for a correct and simple installation of the system, whatever your expertise and technical competence.*

Thank you again, and keep up the good work.

CONTENTS







1	General Safety Information	2
2	Precautions.	3
3	Description of the appliance	4
4	Identification	4
5	System layout	5
6	Technical specifications.	5
7	Unpacking the product.	7
8	Handling.	7
9	Installation area	8
10	Installation on flat roofs with ballast.	9
11	Hydraulic connections.	10
12	Exploded view	11
14	Installation	13
29	Source water system	28
30	Filling and emptying.	29
31	Device cleaning and maintenance	29
32	Recycling and disposal	29
33	External maintenance.	30

CONFORMITY

Solar collectors *comply* with EN 12975-1, ISO 9806 and Solar Key-mark certification.

GENERAL INFORMATION

1 GENERAL SAFETY INFORMATION

-  Check that the product is complete, undamaged and as ordered as soon as you receive it. Report any discrepancies or damage to the Romstal's dealer who sold it.
-  This product must be installed by a legally qualified heating engineer. On completion of the installation, the installer must issue the owner with a declaration of conformity confirming that the installation has been completed to the highest standards in compliance with the instructions provided in this instruction manual, and that it conforms to all applicable laws and standards.
-  This product must only be used for the purpose for which it is designed and made, as specified by US.Romstal declines all responsibility, contractual or other, for damage to property or injury to persons or animals caused by improper installation, adjustment, maintenance or use.
-  All servicing and repairs must be performed by a qualified heating engineer.
-  Solar collectors must be installed with the correct mounting kit (which includes all necessary rails and brackets) as listed in the Catalogue.
-  A protective film is applied to the glass of the solar collector to protect the absorber against solar irradiation and prevent the solar collector from becoming too hot if it is not going to be put into service immediately. Fill the system, but do not remove the film until you are ready to put the system into service. Take care when removing the film as it may be electrostatically charged. Do not leave the protective film in place for longer than 12 months. Once removed, the protective film cannot be re-used. Dispose of the protective film in compliance with legislation governing the disposal of PVC.

The following symbols are used in this manual:

 **CAUTION!** = Identifies actions that require caution and adequate preparation.

 **STOP!** = Identifies actions that you MUST NOT do.

- ⚠** The system must be installed by specialist personnel. Use only the assembly material supplied with the solar collector. The supporting framework and all masonry or brickwork fixing points must be checked by a person expert in static loading, and must be suitable for the nature of the installation site.
- ⚠** The solar collector must only be installed on roofs or frames that are strong enough to support its weight. The strength of the roof or frame must be verified on site by a person expert in static loading before the solar collector is installed. During this process, it is important to verify the suitability of the supporting frame to hold the screw fasteners that fix the solar collector in place. An expert in static loading must verify that the entire frame complies with relevant standards, especially in areas liable to snow and areas exposed to high winds. Conditions (gusts of wind, formation of wind vortices, etc.) at the point where the solar collector is to be installed must be carefully considered since these can increase the loads on the supporting structure.
- ⚠** Solar collector pipes must be connected through a (yellow-green) connector of at least 16 mm² Cu (H07 V-U o R) to the potential compensation main bar. If a lightning rod is already installed, collectors can be integrated in the existing system. If this is not the case, it is possible to carry out earthing with a buried earth cable. The earth duct must be laid outside the house. Furthermore, the earth cable must be connected to the compensation bar through a duct having the same diameter.
- ⚠** All pipes in the water circuit must be insulated in conformity to relevant standards. Lagging and insulation must be protected against damage by the weather and birds and animals.
- ⚠** The collector is suitable for a minimum inclination of 15°, up to a maximum of 75°.
- ⚠** This instruction manual is an integral part of the product. It must be kept safe and must ALWAYS accompany the product, even if it is sold to another owner or transferred to another user or to another installation. If you lose this manual, order a replacement immediately. Keep the product purchase documents to be presented to Romstal's authorised Technical Assistance Service to request a service call under warranty.
- ⚠** Size the solar expansion tank so as to ensure complete absorption of the expansion of the fluid contained within the system, with reference to the prevailing regulations on the matter. In particular, consider fluid characteristics, considerable fluctuation of service temperature and vapour that might be generated during solar collector stagnation stage. Proper size of expansion tank ensures setting off of all volume changes of the heat transfer fluid, avoiding excessive pressure increase. Limited pressure changes avoid reaching safety valve opening pressure and the consequent fluid drainage.

2 PRECAUTIONS

- ⚠** Always wear safety goggles when drilling. Always wear safety shoes, cut-proof protective gloves and a safety helmet when performing installation work.
- ⚠** Before beginning installation work on roofs, install the necessary fall prevention and fall arrest devices and ensure that all applicable safety standards are applied. Use only tools and materials that conform to the safety standards that are applicable in the place of work.
- ⚠** Use only overalls with harness (with lacing or restraining belt, connection ropes or bands, fall dampeners, heat sinks) certified for the risk detected according to the type of covering and allowing operating in complete safety.
- ⚠** The use of ladders leaned against walls can lead to serious falls if the ladder slips, slides or falls. When using ladders, always ensure that they are stable, and that suitable ladder stops are present. If possible secure the ladder with hooks. Make sure that there are no live electrical wires near the ladder.
- ⊖** Never attempt to install the system without using suitable personal protection equipment and without following all applicable occupational safety standards.
- ⊖** Do not touch the product when barefoot or wet if it has any electrical accessories installed in it.
- ⊖** Never clean or service the storage cylinder without first turning the mains power switch OFF to disconnect all electrical accessories (if fitted) from the mains electricity supply.
- ⊖** If solar plant pressure decreases, it is forbidden to top up with only water as there is a danger of freezing and overheating.
- ⊖** Do not dispose of packaging material into the environment, or leave it within the reach of children, since it can become a potential hazard. Dispose of packaging material in compliance with applicable legislation.

3 DESCRIPTION OF THE APPLIANCE

The solar collectors are flat, full plate, vertical collectors, with aluminium absorber, with vertical copper pipes welded onto it, ending at their upper and lower ends, in two horizontal headers. The thermal fluid circulates between the vertical and horizontal pipe grid.

The surface processing of the aluminium sheet is of selective quality, achieved with the ecological "Sputtering" method by TINOX. These surfaces have the great advantage while absorbing solar energy and operate as black bodies (high absorptivity), when they radiate themselves, they operate as mirrors (minimum radiation $\epsilon \leq 3.5\%$), thus achieving a significant decrease of the collector's thermal losses.

- The copper grid consists of vertical $\varnothing 8$ tubes, spaced at 85mm intervals and welded onto the 0,4 mm aluminium sheet with Laser welding. The small distance between the tubes, the thickness of the aluminium and the proper welding, maximizes the heat transfer from the heated aluminium sheet to the vertical pipes and finally to the thermal fluid which circulates inside.
- To reduce flow friction the headers have a $\varnothing 22$ diameter.
- The absorbers are placed in a pre-painted, high quality, alloy-steel frame, with 0,42mm thickness.
- On the front, there is a clear safety glass cover (low iron, mistlite, tempered), 3,2mm thick, that is fitted on the pre-painted alloy-steel frame, by injecting the polymeric material Colofast® by BASF.
- The polymeric Colofast® offers flawless permanent connection between glass and steel, robustness and forms a solid peripheral structure for the upper section of the casing. It is also impermeable and offers perfect finish.
- On the back of the absorber, there is glass-wool thermal insulation with 40 kgr/m³ density and 30mm thick.
- The operating pressure of the closed circuit of the collectors can be 6 or 10 bar, depending on the design, considering that collectors can withstand even higher pressures.
- The collectors are designed for installation on flat roofs and pitched tiled roofs, by using the appropriate support frames that are available as accessories.

4 IDENTIFICATION

Data label

To be applied to the back of the solar collector on installation

FLAT SOLAR PANEL
DIMENSIONS : 1235x2020x85mm
GROSS AREA : 2.50 M ²
APERTURE AREA: 2.38 M ²
ABSORBER AREA: 2.37 M ²
WEIGHT EMPTY : 35.4 kg
MAX OPER. PRESSURE : 10 Bar
STAGNATION TEMPERATURE : 180° C
ABSORBER CAPACITY: 1.55 L
MAX GLYCOL CONCENRATION: 53%
PRODUCTION DATE : 2022
SERIAL NUMBER
2201262500002140
Made in E.U

Data label

To be applied to the back of the solar collector on installation

FLAT SOLAR PANEL
DIMENSIONS : 1235x1625x85mm
GROSS AREA : 2.00M ²
APERTURE AREA: 1.90M ²
ABSORBER AREA: 1.90M ²
WEIGHT EMPTY : 29.15kg
MAX OPER. PRESSURE : 10 Bar
STAGNATION TEMPERATURE : 180° C
ABSORBER CAPACITY: 1.38 L
MAX GLYCOL CONCENRATION: 53%
PRODUCTION DATE : 2022
SERIAL NUMBER
2201262500002382
Made in E.U

! If these plates or any other means of clearly identifying the product are defaced, removed or lost, proper installation and servicing may be rendered difficult.

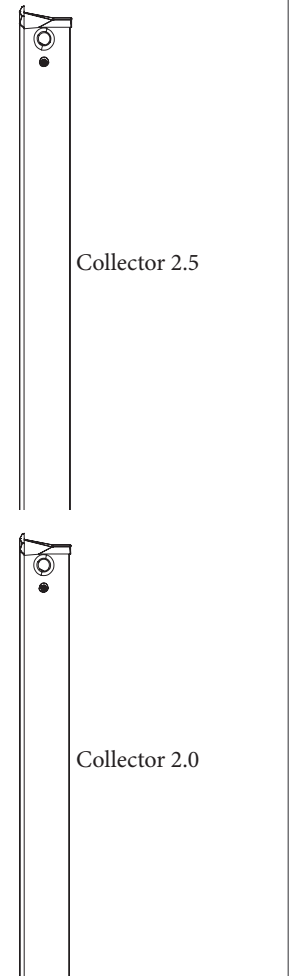

5 SYSTEM LAYOUT

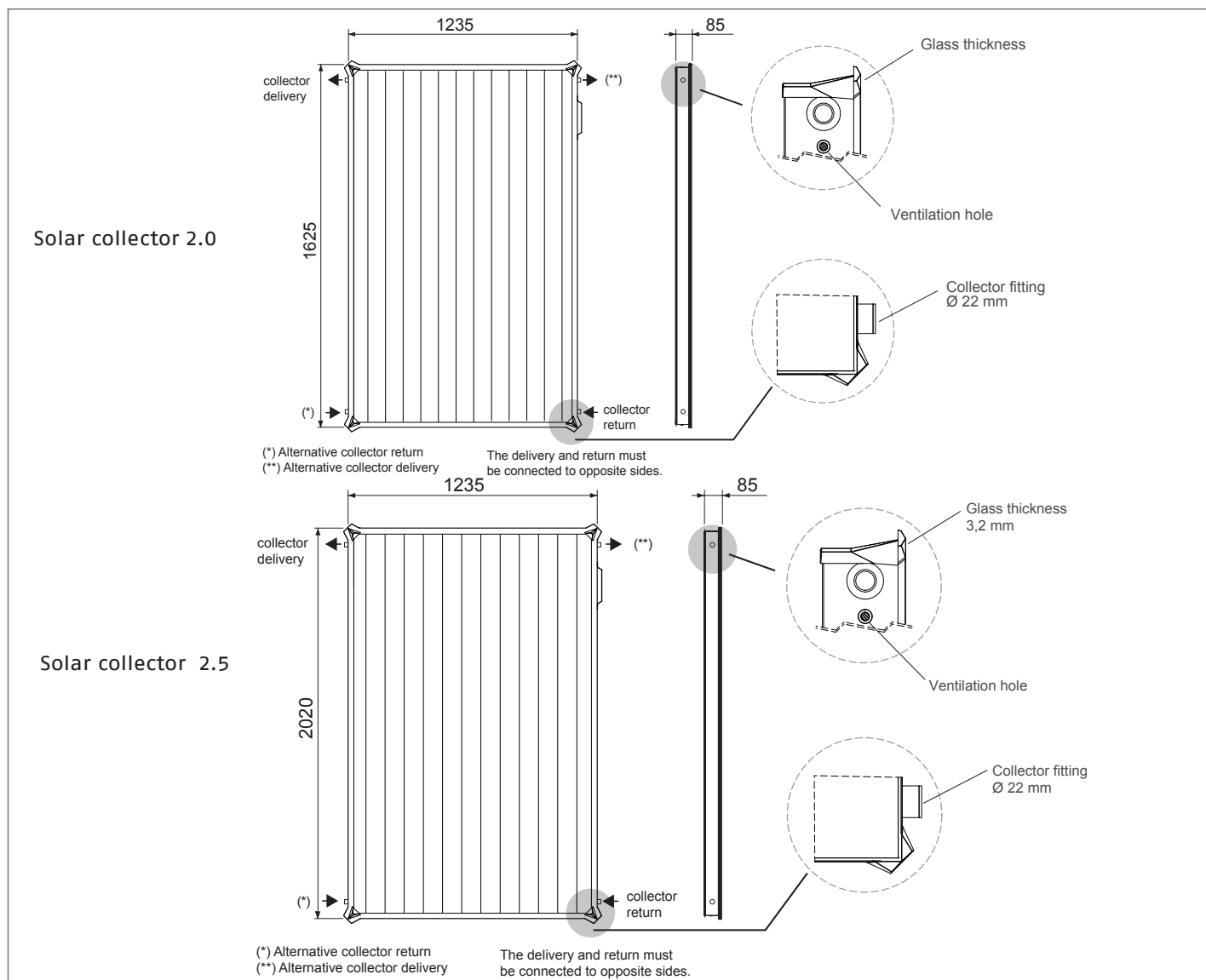

6 TECHNICAL SPECIFICATIONS

DESCRIPTION	Collector 2.0	Collector 2.5	
Total area	2,00	2,49	m ²
Exposed area	1,91	2,39	m ²
Effective absorption area	1,90	2,37	m ²
Hydraulic connections	22	22	∅
Empty weight	29,15	35,4	kg
Liquid content	1,38	1,55	kg
Recommended flow rate for each line per m ² of collector (*)	50	50	l/(m ² h)
Recommended flow rate for each line per m ² of collector (**)	30	30	l/(m ² h)
Maximum flow rate for each line per m ² of collector	60	60	l/(m ² h)
Minimum flow rate for each line per m ² of collector	20	20	l/(m ² h)
Glass thickness	3,2	3,2	mm
Thickness of glass wool insulation	30	30	mm
Absorption (α)	95	95	%
Emissivity (ε)	4	4	%
Maximum permitted pressure	10	10	bar
Stagnation temperature	180	180	°C
Maximum number of collectors in a line	10 Vertical	10 Vertical	n°
Installation	Vertical	Vertical	-
Glass	Low Iron Prismatic Tempered	Low Iron Prismatic Tempered	-
(*) recommended flow rates in the hottest climatic bands			
(**) recommended flow rates in the medium/cold climatic bands			

Description	Collector 2.0	Collector 2.5	Units
Maximum efficiency (η_0) (*)	0,762	0,770	-
Thermal dispersion factor (a_1) (*)	2,99	3,18	W/(m ² K)
Thermal dispersion temperature dependence factor (a_2) (*)	0,027	0,021	W/(m ² K ²)

(*) Value referred to the opening area. Test according to ISO 9806 referred to mix of water and 33.3% glycol, flow rate 160 l/h and direct exposure $G = 800\text{W/m}^2$.
 $T_m = (\text{Coll.}_{inlet_temp.} + \text{Coll.}_{outlet_temp.})/2$
 $T^*m = (T_m - T_{ambient})/G$

Pressure drop in solar collectors (*)

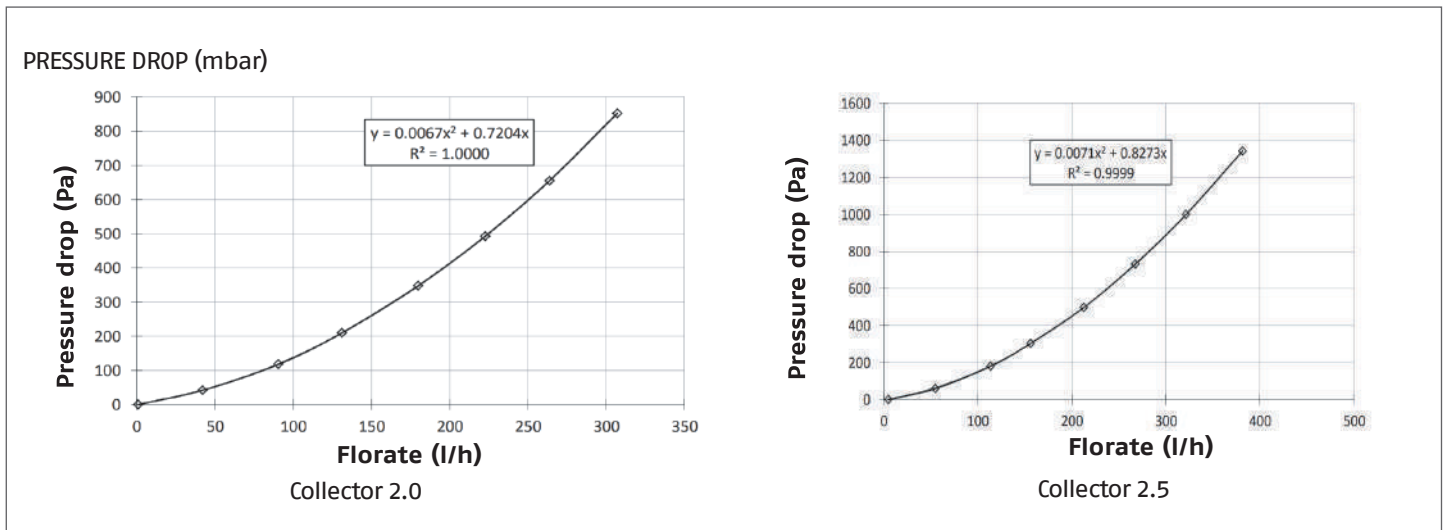

(*) With antifreeze-water mix of 33,3% / 66,7% and heat transfer medium temperature = 20°C.

WIND AND SNOW LOADS ON COLLECTORS

The maximum allowable load for wind and snow (possibly combined) on the collector surface is 500 Pa (corresponding to the wind speed of 130 km/h).

To determine the maximum wind speed consider:

- building height
- solar system site
- exposure and topography (area/buildings)

The maximum snow load depends on the region and the altitude of the area.

! Prevent the accumulation of snow on collectors by installing a snow-guard grille over collectors, or remove snow on a regular basis

7 UNPACKING THE PRODUCT

Solar collectors are supplied in packages containing 1, 2 or 5 panels

Pallet contents:

- collector
- document envelopes containing instruction manual

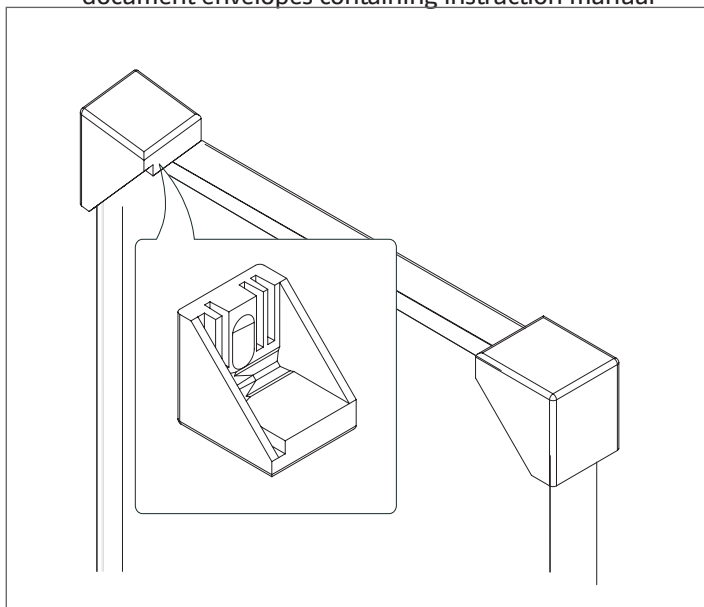

⚠ The instruction manual is an integral part of the solar connector. Once located, read it thoroughly and keep it safe.

⚠ **STORE IN A DRY PLACE AND DO NOT EXPOSE TO DIRECT SUNLIGHT UNTIL THE TIME OF INSTALLATION!** The packaging is not designed to protect the product against rain or humidity. It can also degrade if exposed to direct sunlight. Failure to comply with these precautions could lead to irreparable damage to the product.

8 HANDLING

- Separate the solar collector from the wooden pallet by removing the film wrapping

Once you have removed the outer packaging, proceed as follows to unpack and handle the solar collector:

- Tilt the solar collector slightly and grip it at the four points shown (A) to lift it.
- Use a hoist or other suitable lifting equipment to hoist the solar collector on to the roof.

Data label

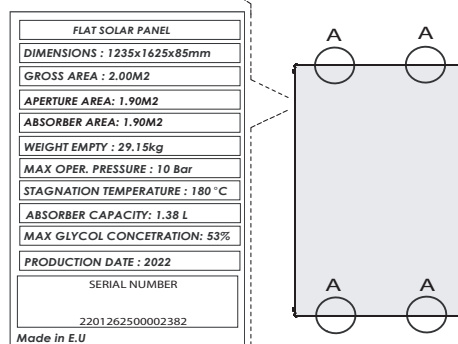

⚠ Wear suitable personal protective equipment and use suitable safety devices.

⊘ Do not dispose of packaging material into the environment, or leave it within the reach of children, since it can become a potential hazard. Dispose of packaging material in compliance with applicable legislation.

⊘ Do not lift the solar collector by its water fittings.

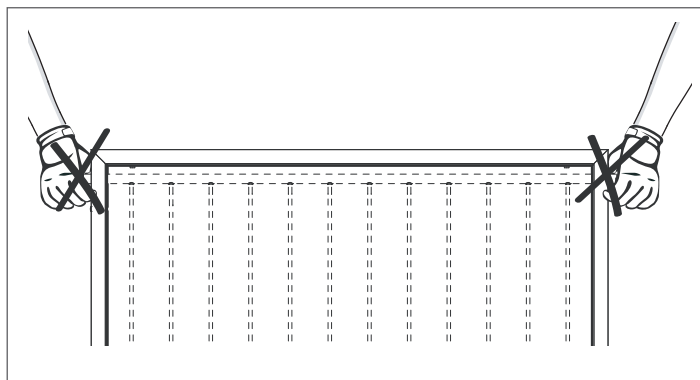

9 INSTALLATION AREA

Select the best possible orientation for the solar collectors (ideally facing south). Avoid positions that are shaded by plants, trees, buildings or hills, etc. during the day.

In systems in which the summer load is predominant (production of domestic hot water) aim the collector from east to west with a variable inclination from 20° to 60°. The ideal direction is southwards, with inclination equal to the latitude of the location -10°. If the system sustains the greatest thermal load in the winter (as in systems that combine domestic hot water production with central heating), install the collectors facing south (or south-east or south-west) at an angle greater than 35°. The ideal orientation is southwards, at an angle equal to the latitude of the location plus 10°.

Remove all gravel and detritus from the surface on which the system is to be installed. Do not use flat roof or sloping roof mounting frames to install any other equipment. They are designed only for use with our solar water heating systems.

The installation of the solar field changes the pre-existing structure of the roof. It is necessary to check and possibly adapt all the roof elements to prevent any seepages or damages caused by wind and/or snow.

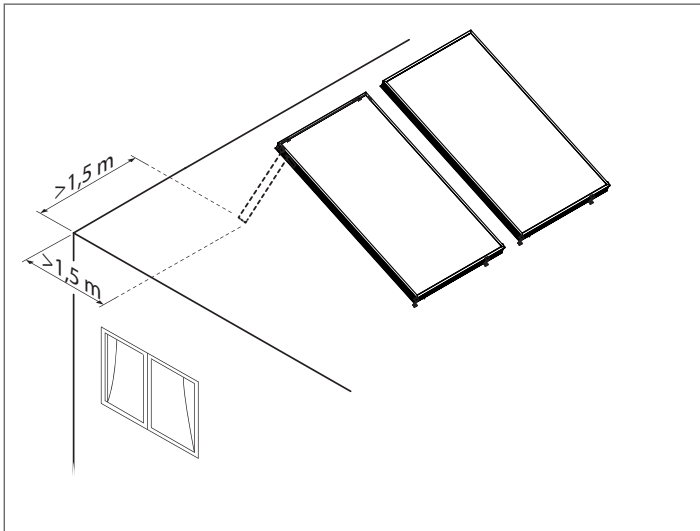

⚠ Collectors must be installed at a safety distance from active parts of electric lines and electric systems as required by the laws and regulations in force in the country of installation

In the absence of specific rules, the minimum installation distance required minus the side movements of conductors due to the action of the wind and of the lowering in height due to thermal conditions is as follows:

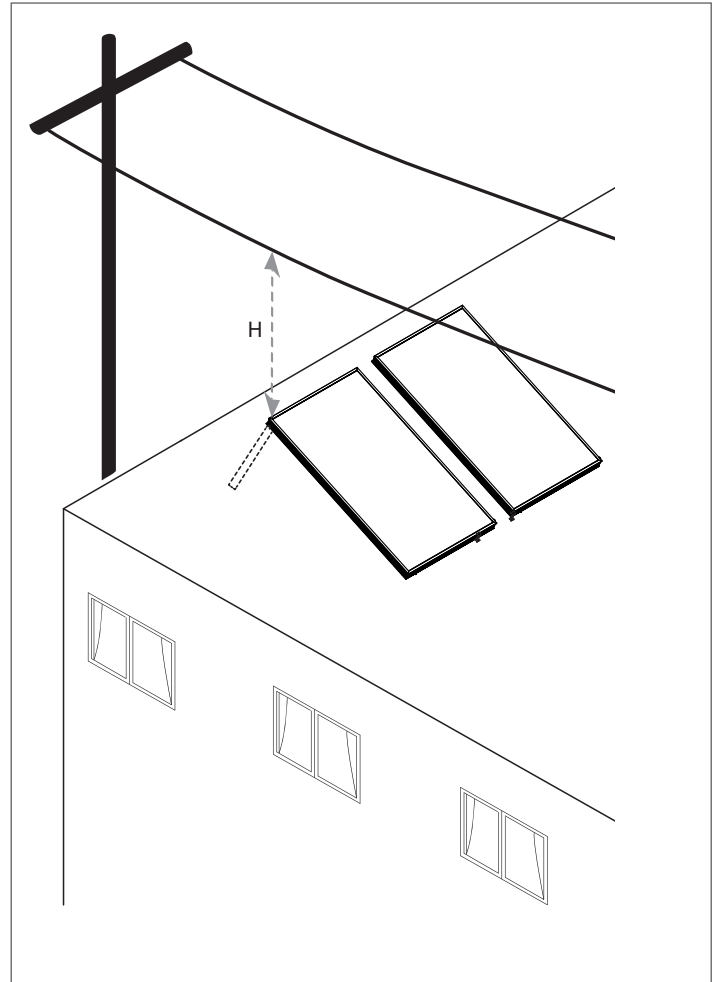

Voltage range	H	
< 1 kV	3	m
1 ÷ 30 kV	3,5	m
30 ÷ 132 kV	5	m
< 132 kV	7	m

⚠ Contact with open, live electrical wires may lead to electrocution and may even be fatal.

⚠ Non-electrical works near live unprotected electric ducts with which a contact is possible must be carried out in accordance with laws and regulations in force in the country of installation.

10 INSTALLATION ON FLAT ROOFS WITH BALLAST

For checks of allowable loads contact a specialised technician.

In case of installations on flat roofs that cannot be drilled use ballasts (not supplied) fairly distributed on all the bearing points, as shown in the figure.

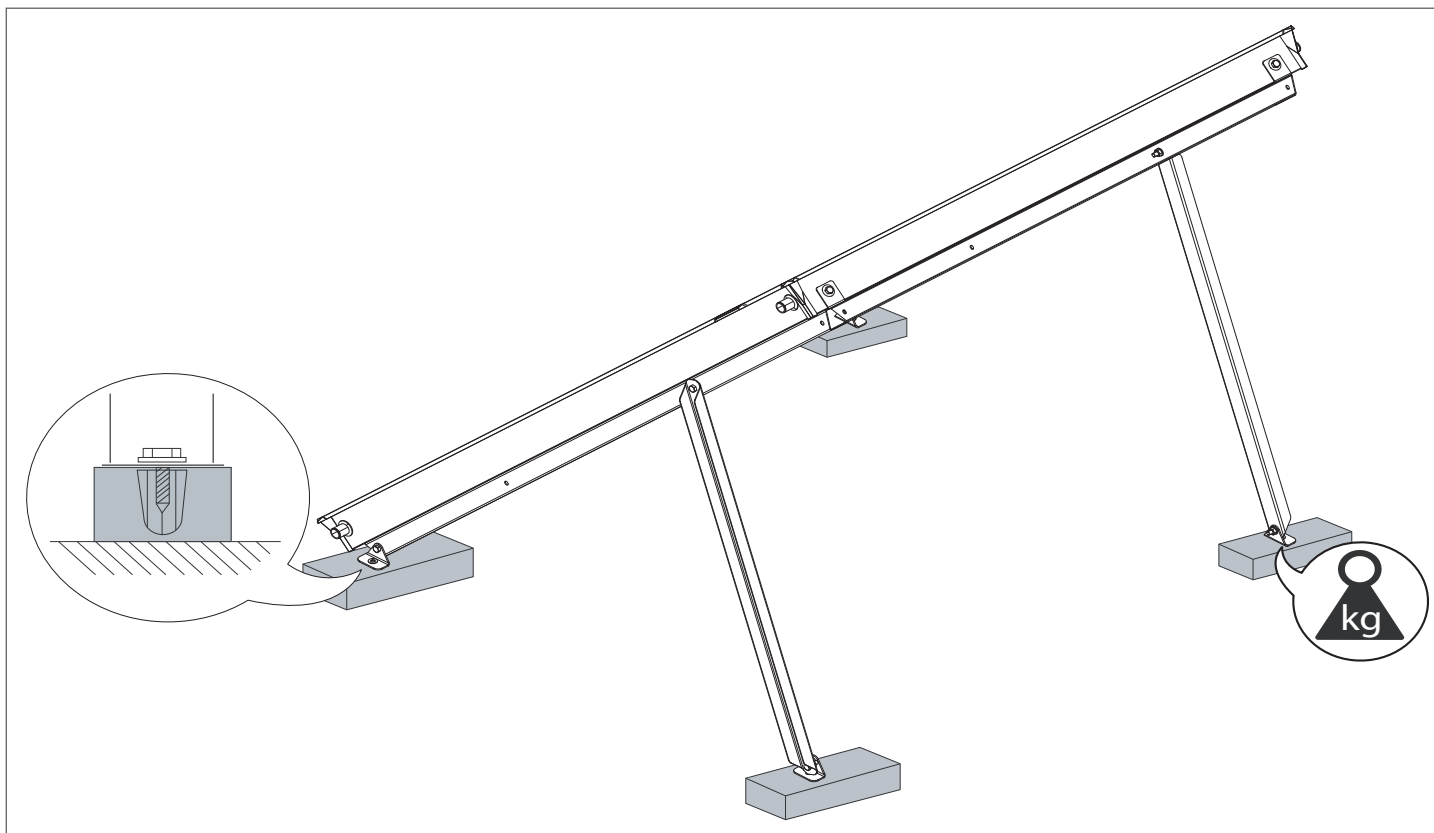

Wind speed, km/h	Inclination angle of solar collectors	Mass in kg, distributed on the various bearing points, to secure a collector from wind lifting
100	30°-45°	135
130	30°-45°	255
150	30°-45°	355

11 HYDRAULIC CONNECTIONS

! During installation, pay attention to the position of the probe with respect to the collector. The collector probe must always be in the upper section of the panel as indicated in the figures below.

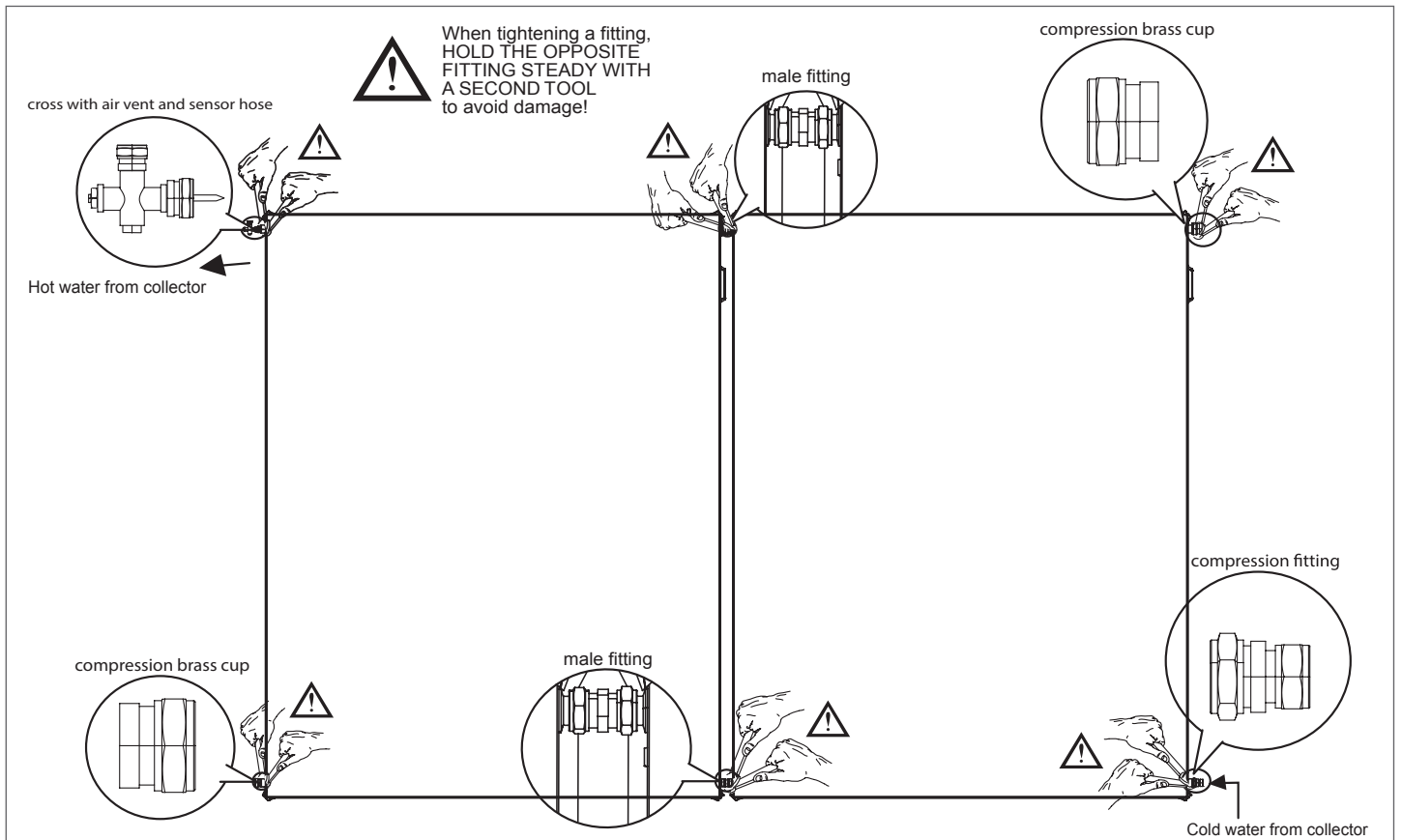

Vertical configuration

Collectors are connected with each other so that the heat transfer fluid crosses them in parallel. Connection with the heat exchange circuit towards the exchanger must be made on the side of probe socket (T) of the last collector of the series (see figure). The positioning of the socket on the collector allows the maximum transfer of heat accumulated in the panels. It is also possible to connect more than one line of solar collectors, both in series (provided that the number of solar collectors does not exceed 10 units per each series) and in parallel. In any case the circuit must be hydraulically balanced (see the following example diagrams).

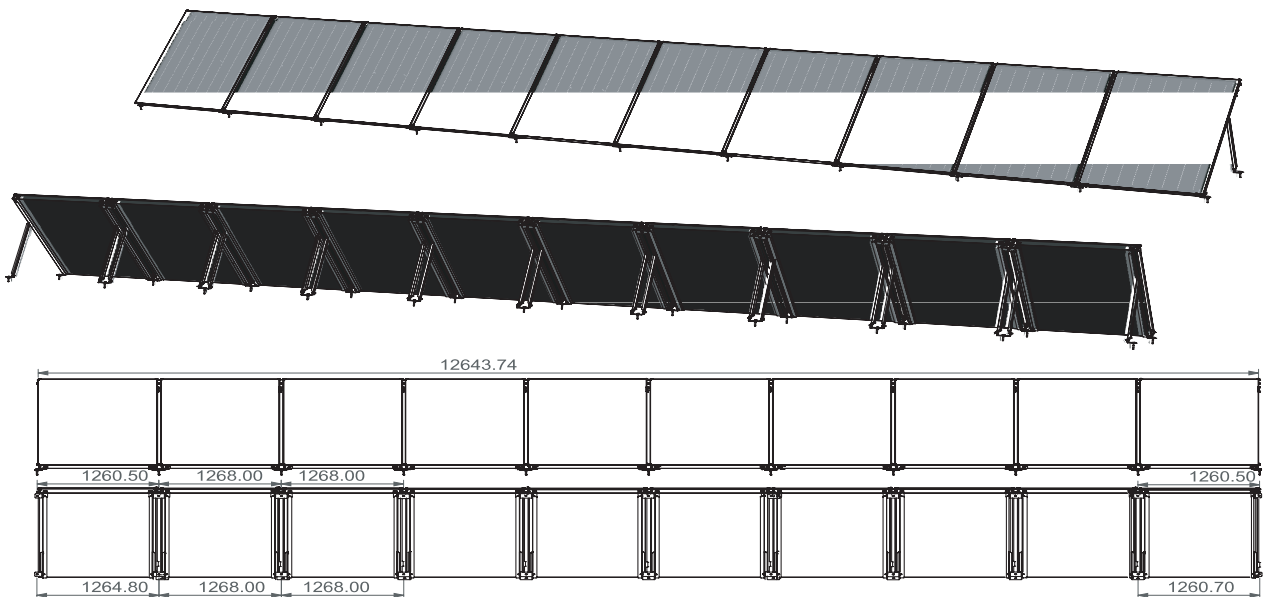

12 EXPLODED VIEW

STAND-ALONE COLLECTOR FLAT ROOF WITH ARRAY

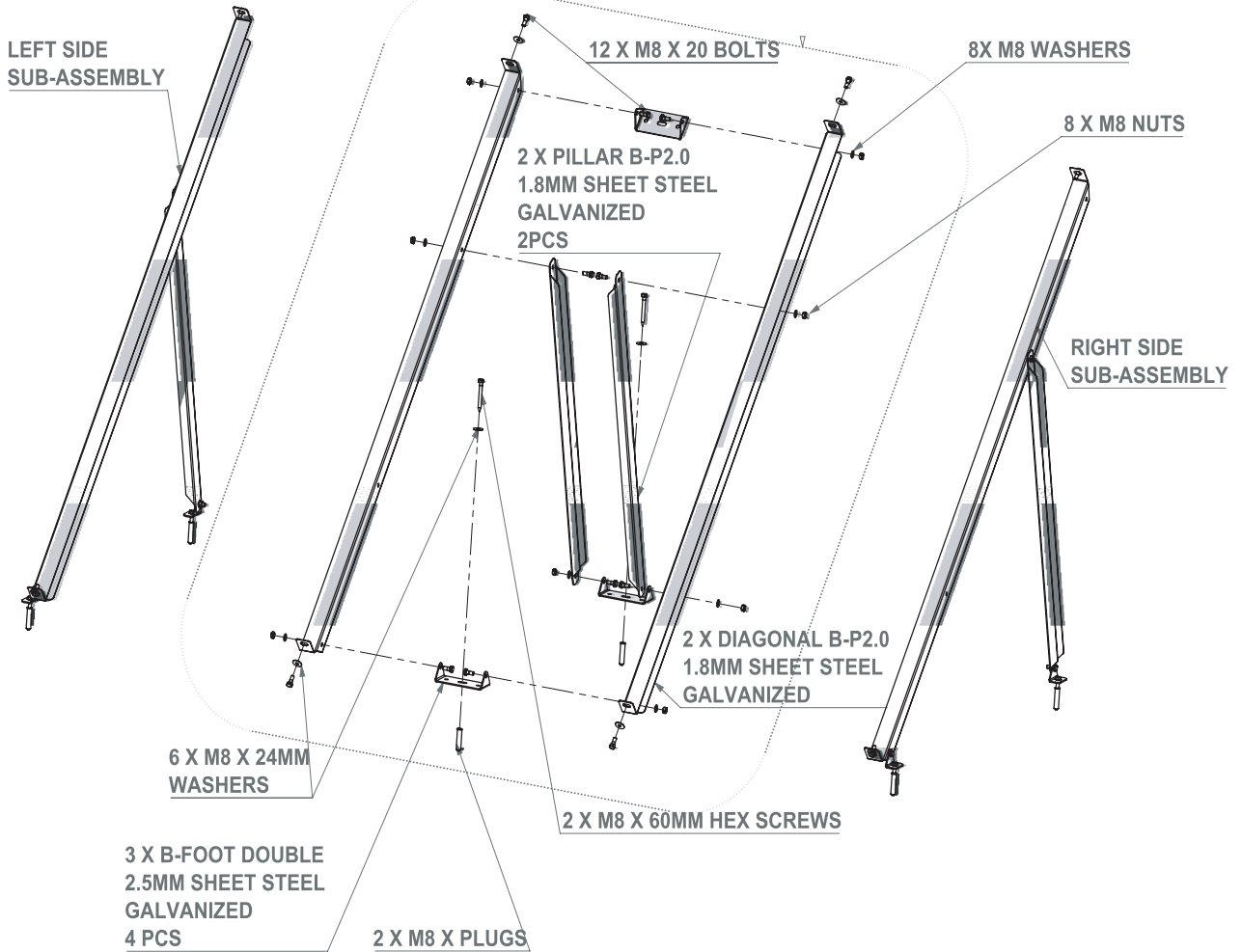
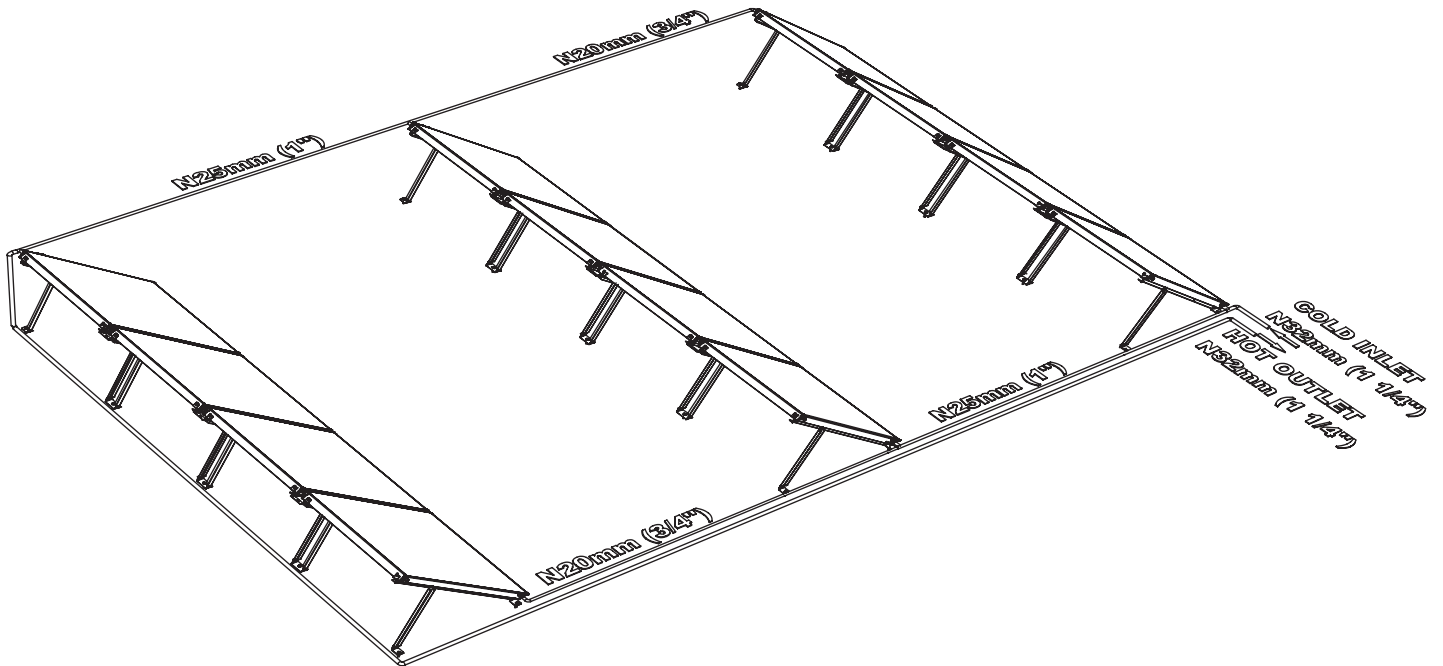

13 EXPLODED VIEW

STAND-ALONE COLLECTOR FLAT ROOF

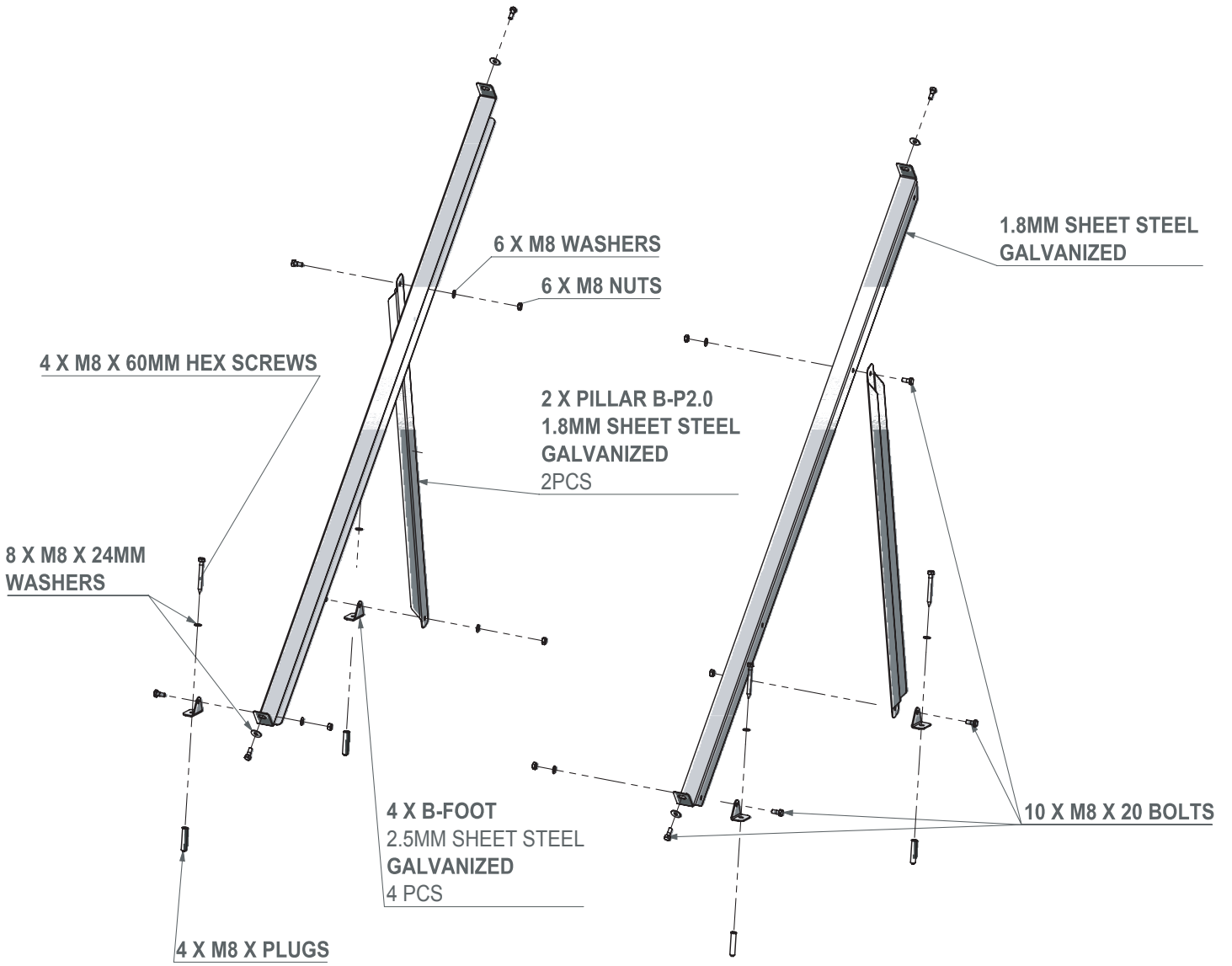

14 INSTALLATION

STAND-ALONE COLLECTOR INCLINED ROOF

CAUTION: Check the capacity of the roof structure to bear the solar heater load in operation with the constructor of the building or contact the local authorities.

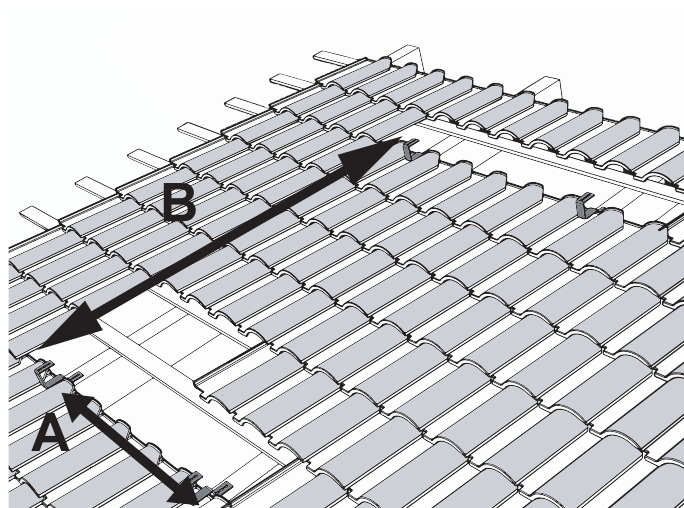

PICTURE 1

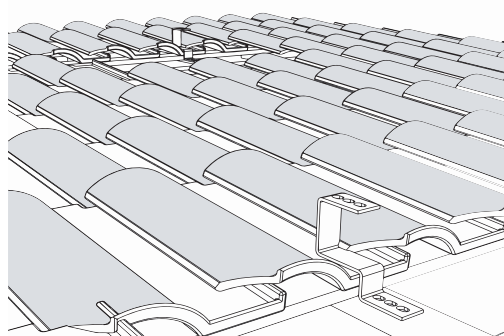

PICTURE 2

STEP 1

Uncover the roof tiles at the lowest and the highest part of the area where the collectors will be installed. Install the 4 AGG brackets (or the AT – triangular type or the AR – special screw, if needed) on the vertical, load-bearing beams with appropriate screws, as shown on the drawing above (pic.2). Make sure that the distances A and B (pic.1) between any of the top holes on each bracket are set according to Table 2. You may take advantage of the fact that there are 3 holes on the top of each bracket to accommodate for different tile sizes. .

TABLE 2

DIMENSIONS (mm)	2.0	2.5	2x2.0	2x2.5
A	1090	1090	1090	1090
B	2000	2400	2000	2400

15 INSTALLATION

STAND-ALONE COLLECTOR INCLINED ROOF

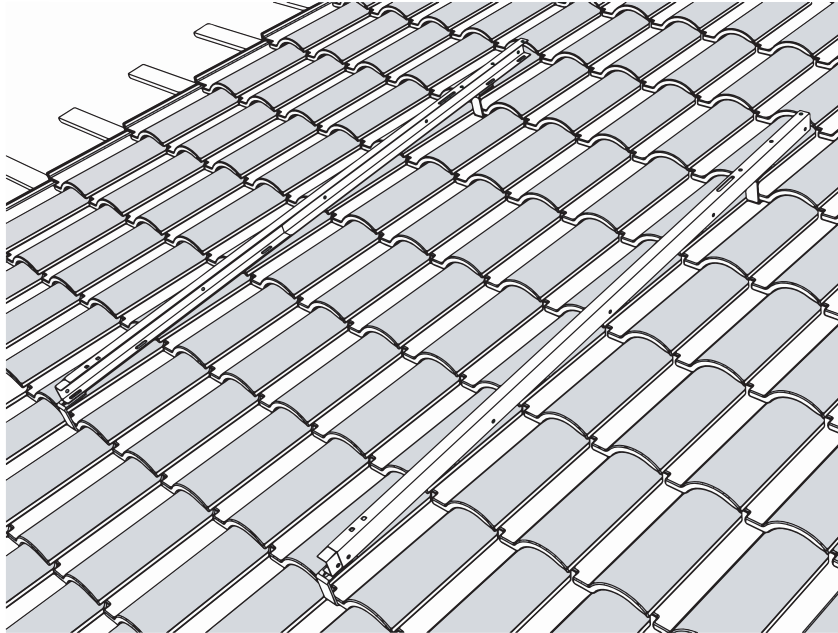

STEP 2

Replace the roof tiles and install the two longitudinal base sections onto the AGG brackets. Make use of the telescopic feature of the sections to adjust them to the appropriate length.

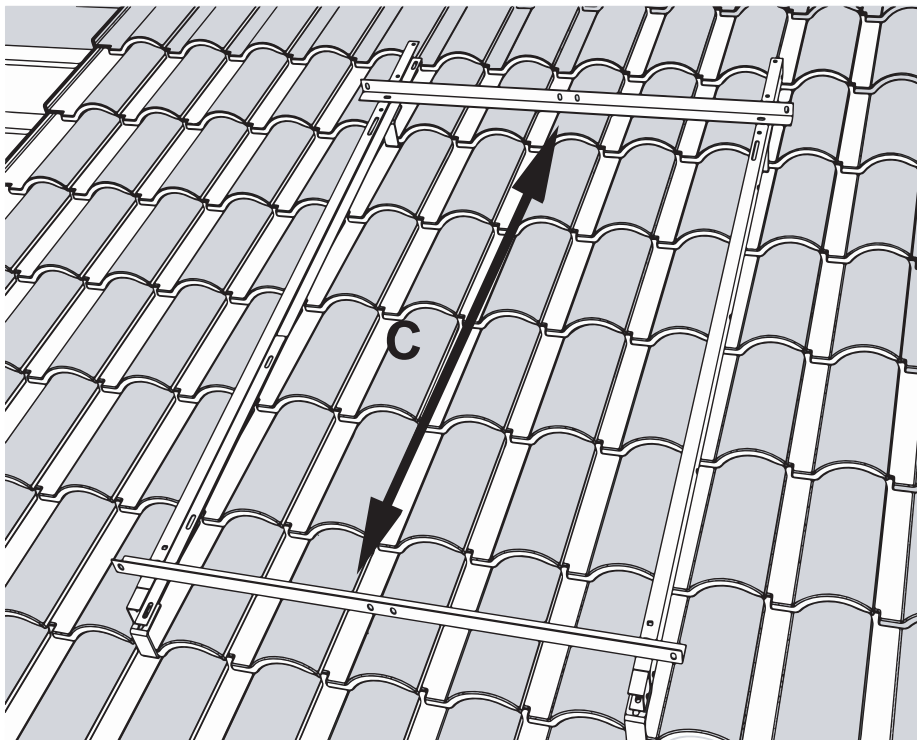

16 INSTALLATION

STAND-ALONE COLLECTOR INCLINED ROOF

STEP 3

Install the two L beams supporting the collector. The distance C between the vertical mounting faces of two beams should be set according to the Table to fit the height of the collector. Secure only the bottom beam and slide the top beam upwards to ease collector installation.

DIMENSIONS (mm)	2.0	2.5	2x2.0	2x2.5
C	1600	1994	1600	1994

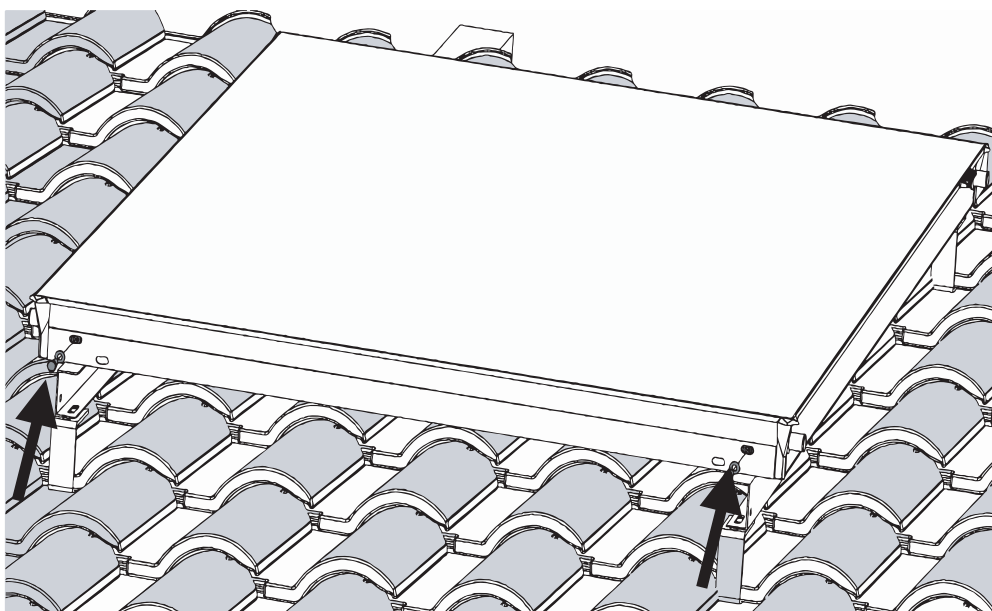

STEP 4

Place the collector(s) on the base assembly. Tighten the bottom securing bolts against the bottom support beam.

17 INSTALLATION

STAND-ALONE COLLECTOR INCLINED ROOF

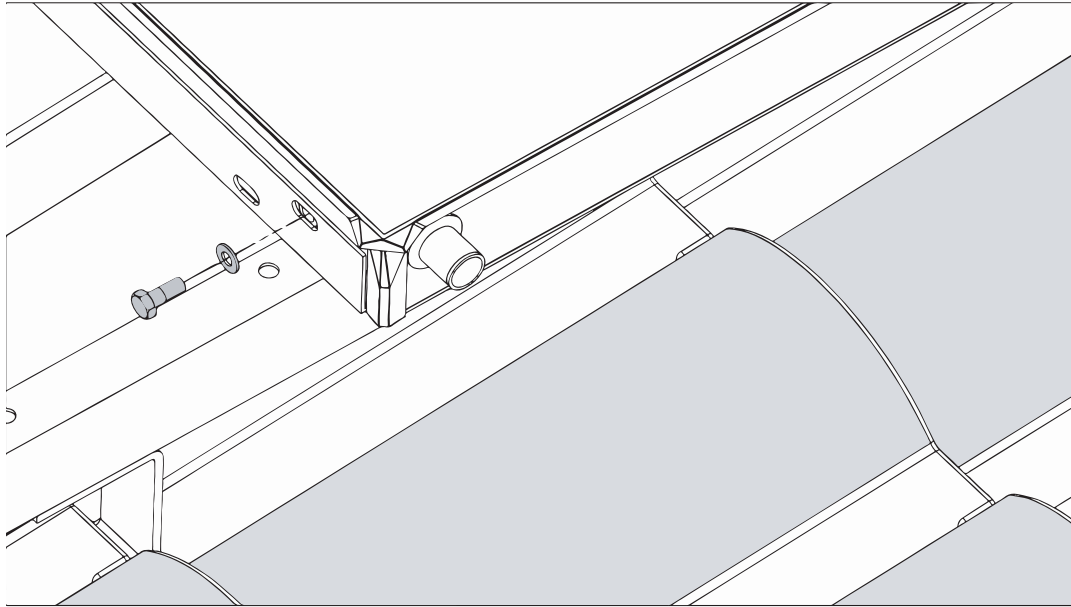

STEP 5

Slide the top support beam against the collector and tighten the support bolts. Tighten the support beam onto the longitudinal base sections.

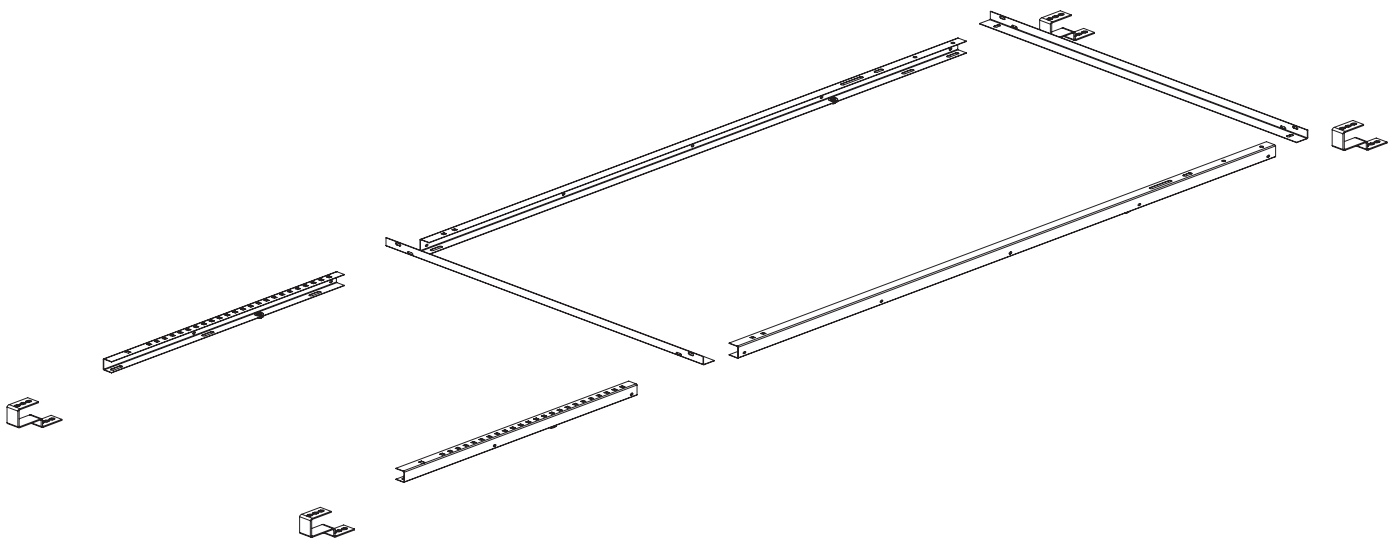

18 INSTALLATION

STAND-ALONE COLLECTOR

STEP 1

Assemble the system as shown in the figure above. Adjust the position of the longitudinal extension for the length of the collector. The dimension above corresponds to the P2.5 collector. The P2.0 collector can be mounted on the main beam at both ends without the need for the extension. Adjustability is built into the system so that different tile sizes and rafter spacings can be accommodated. The dimensions above are the most common dimensions for Roman style tiles.

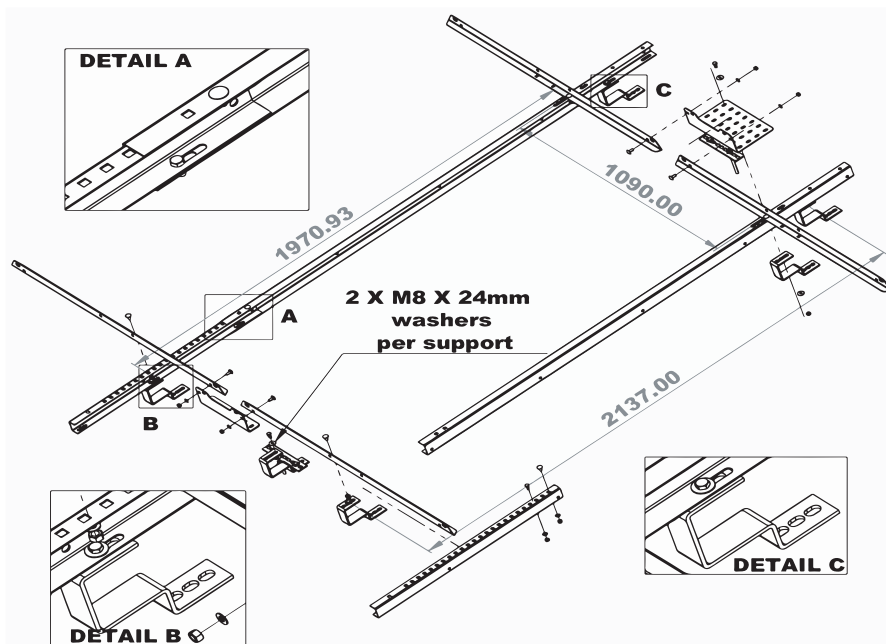

STEP 2

Place the assembled base on the roof and remove as many tiles as necessary at the vicinity where the supports are so that you may observe the roof support structure and adjust the installation accordingly. There are alternative mounting points on both directions on the longitudinal beams and on the middle supports. Additionally there are multiple slots on the AGG supports. Finally there are extension plates in case the rafter spacing is inconvenient. Make sure that the roof structure can support the collector array and the stresses induced and that the points of contact are sound. Mark and drill the holes for the roof dowels.

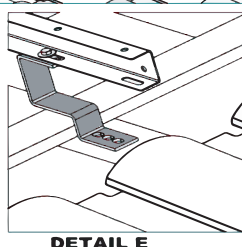
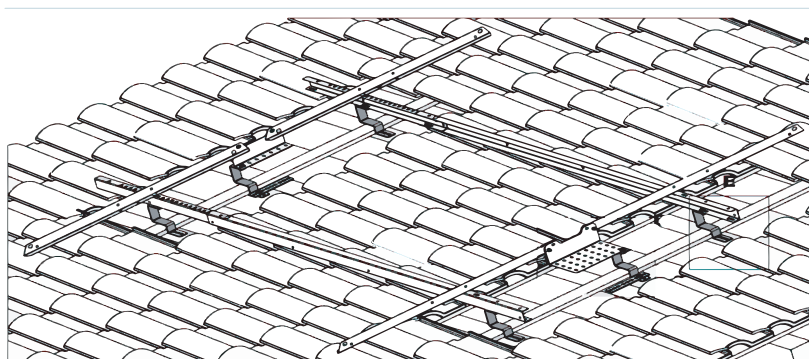

DETAIL E

⚠ Do not remove the collector cover!

19 INSTALLATION

STAND-ALONE COLLECTOR

STEP 3

Install all roof dowels, ensure that the system is stable and geometrically correct, tighten all bolts and replace the roof tiles.

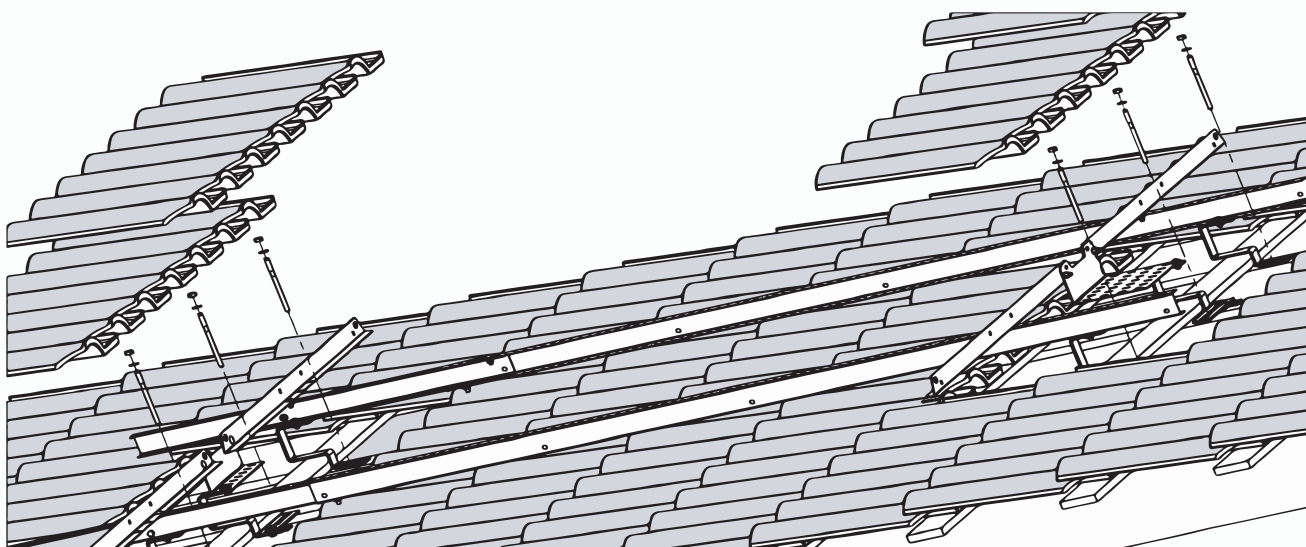

STEP 4

Install the first collector on the rails and tighten collector bolts.

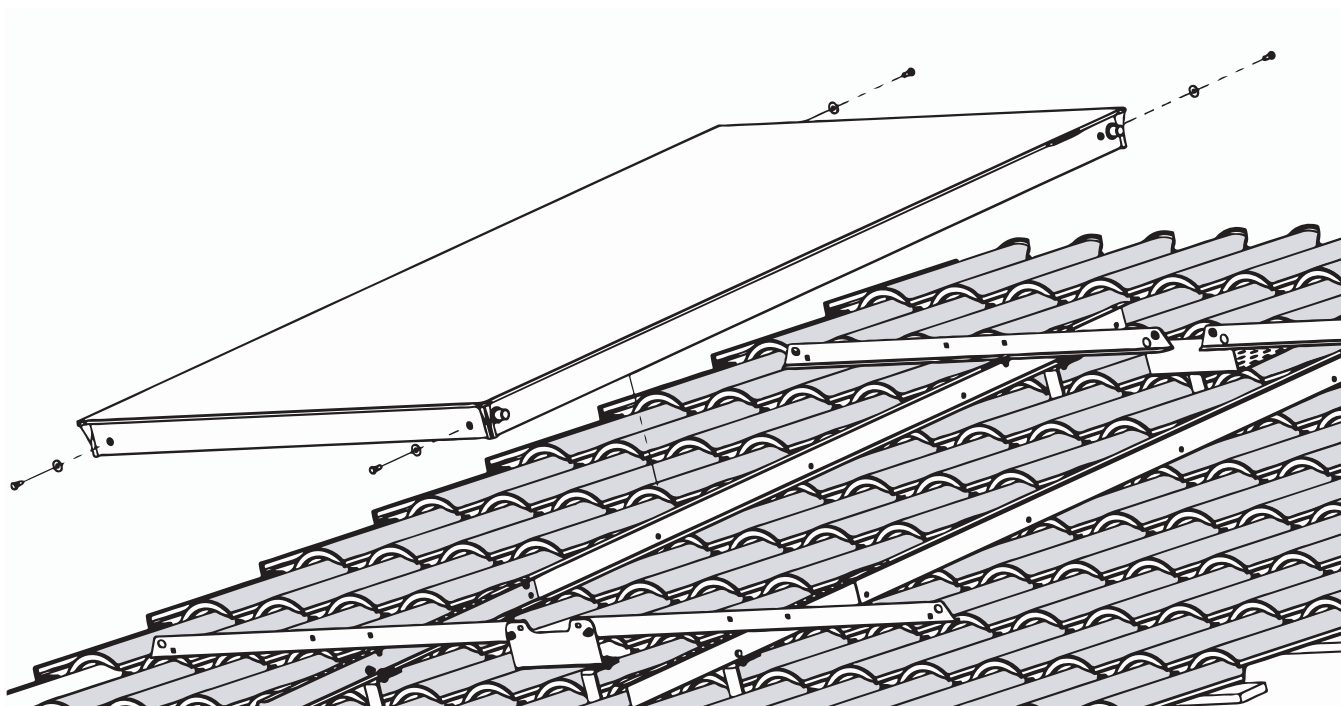

⚠ Do not remove the collector cover!

20 INSTALLATION

STAND-ALONE COLLECTOR**STEP 5**

Install the male to male hydraulic connections on the first collector and slide the second collector into place. Take care not to damage the absorber tubes. Install the collector bolts. Tighten the hydraulic connections and then tighten the collector bolts.

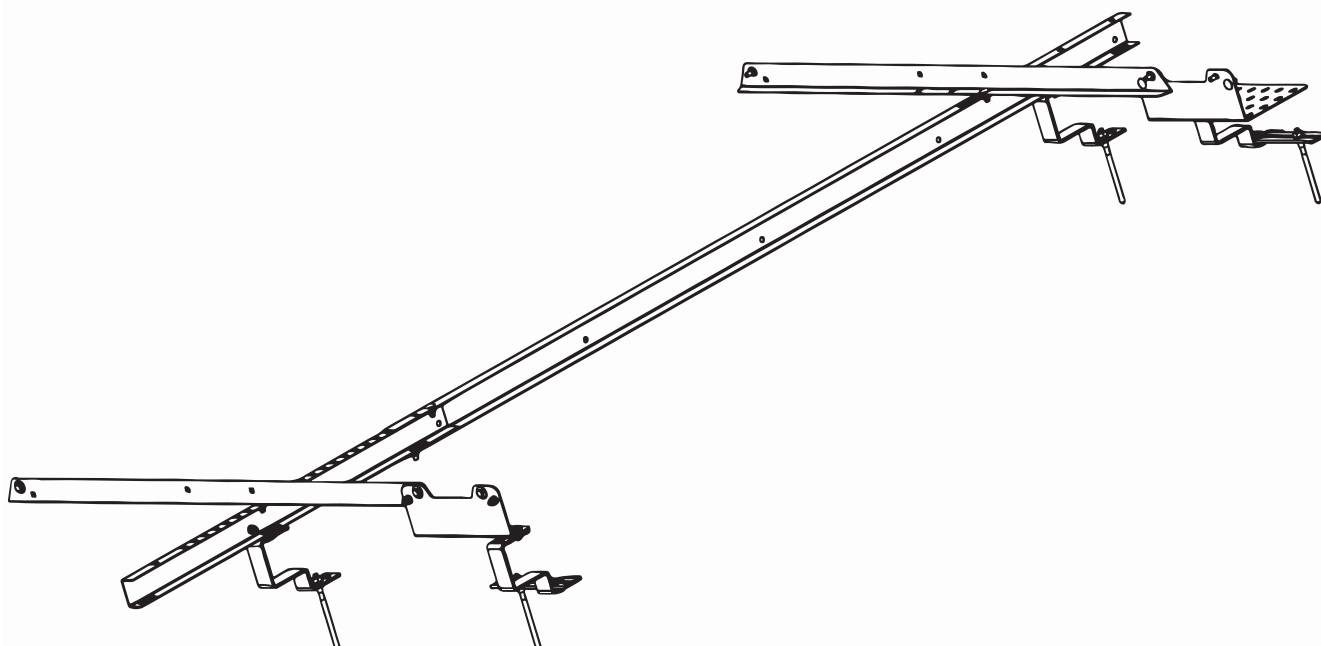
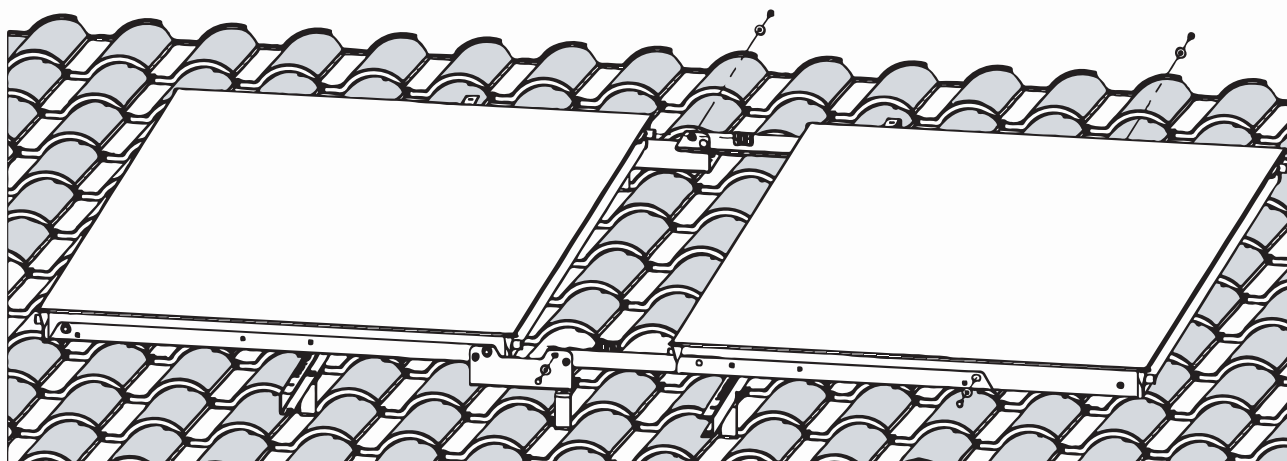
**NOTE**

Arrays of more than two collectors may be created with the ARRAY module as shown above. The array starts with the twin collector system that is shown in the steps above which may be extended either side with the ARRAY module during the above steps.

⚠ Do not remove the collector cover!

21 INSTALLATION

STAND-ALONE COLLECTOR FLAT ROOF

STEP 1

Assemble the right and left side sub-assemblies as shown in the figure. Tighten the bolts so that movement is possible.

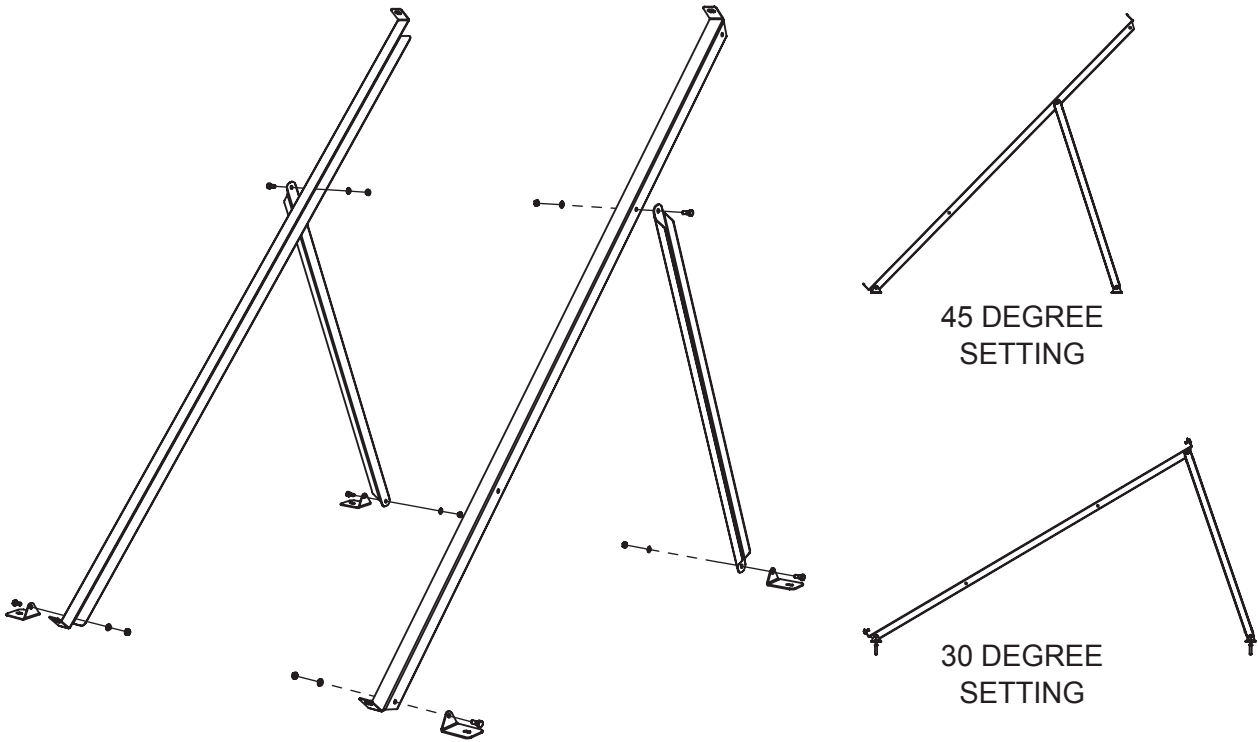

STEP 2

Determine the position of the system on the roof according to the guidelines at the relevant section of this manual. Mark the position of the holes for the front two feet at 1245mm apart and drill appropriate holes for the anchors.

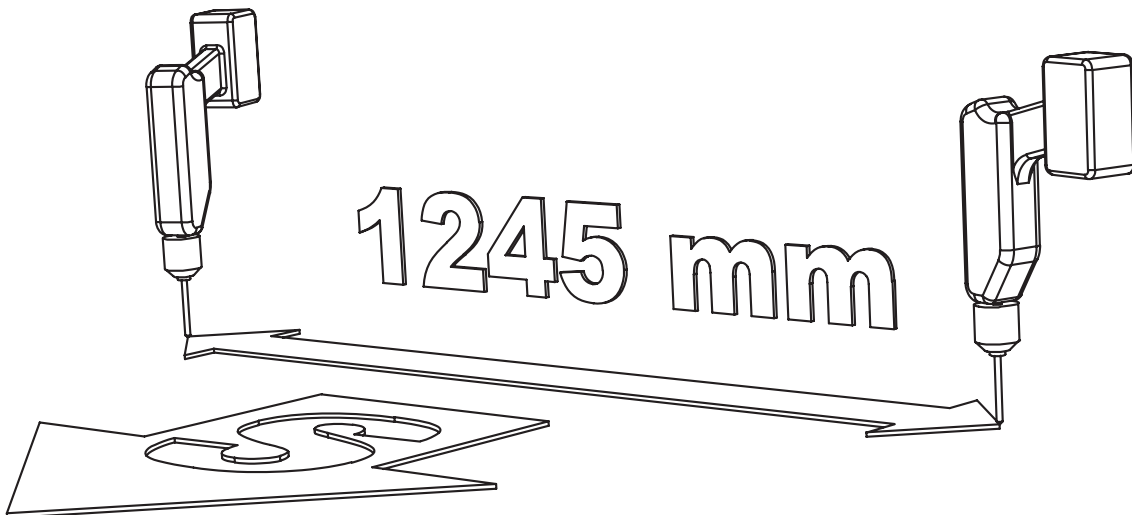

22 INSTALLATION

STAND-ALONE COLLECTOR FLAT ROOF**STEP 3**

Install the front feet at the holes using the appropriate anchors for the roof material and operating conditions. Secure the front feet in position but **DO NOT** tighten the anchors fully yet.

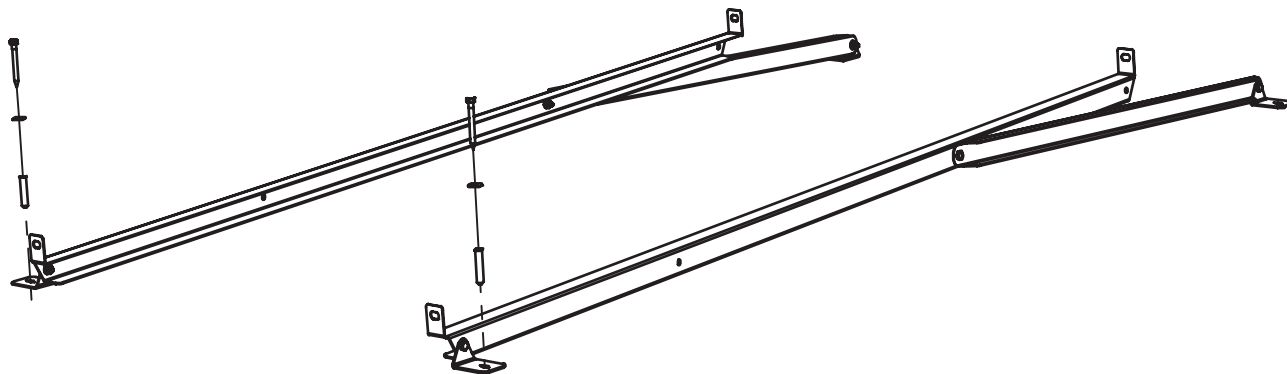
**STEP 4**

Make sure the collector rails are parallel and carefully lower the collector panel into position.

⚠ Do not remove the collector cover!

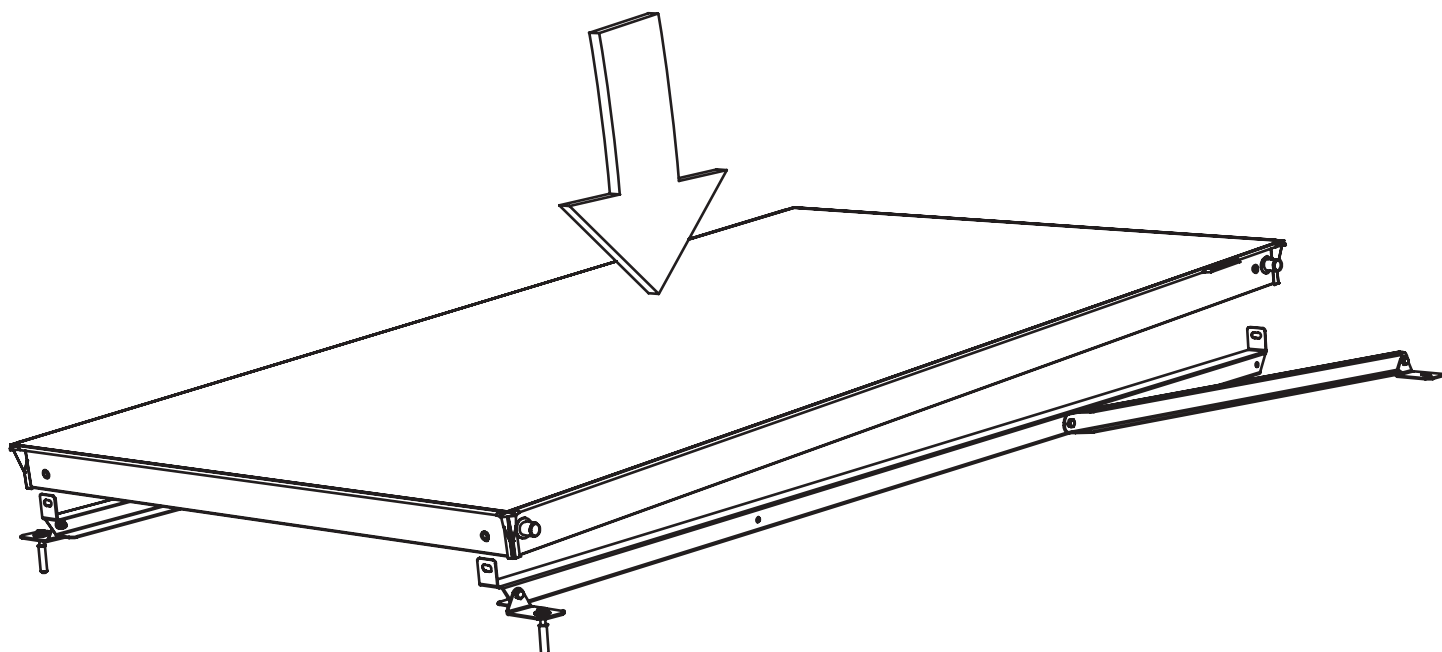

23 INSTALLATION

STAND-ALONE COLLECTOR FLAT ROOF**STEP 5**

Adjust the position of the front feet if necessary and install the 4 collector securing bolts.

NOTE: Use 24mm (wide) washers. Tighten the collector bolts and then tighten the front anchors.

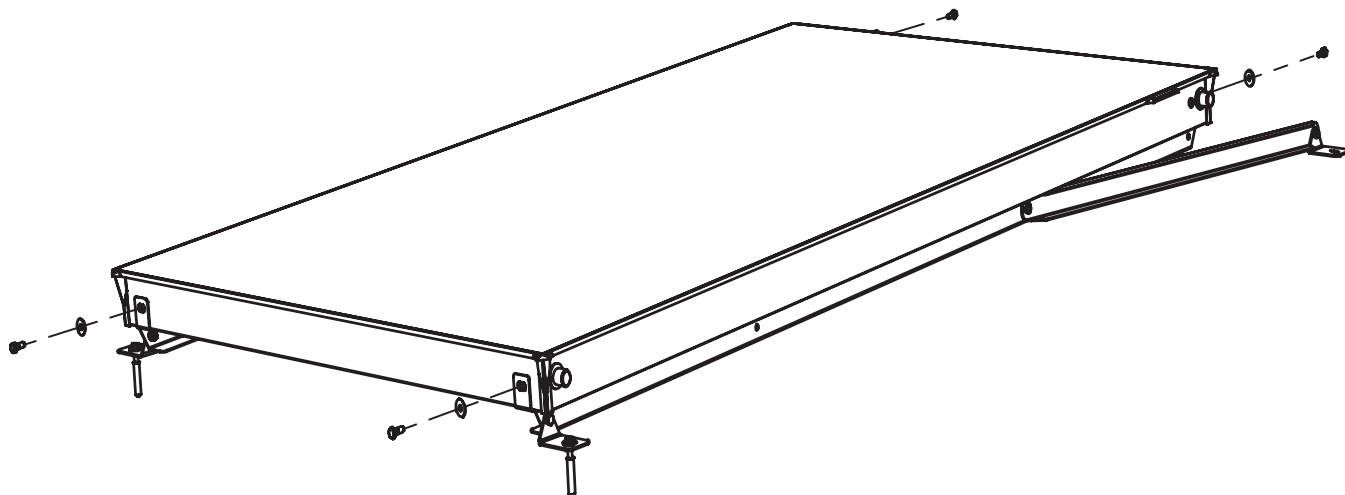
**STEP 6**

Raise the collector in a controlled manner and set it to the desired inclination

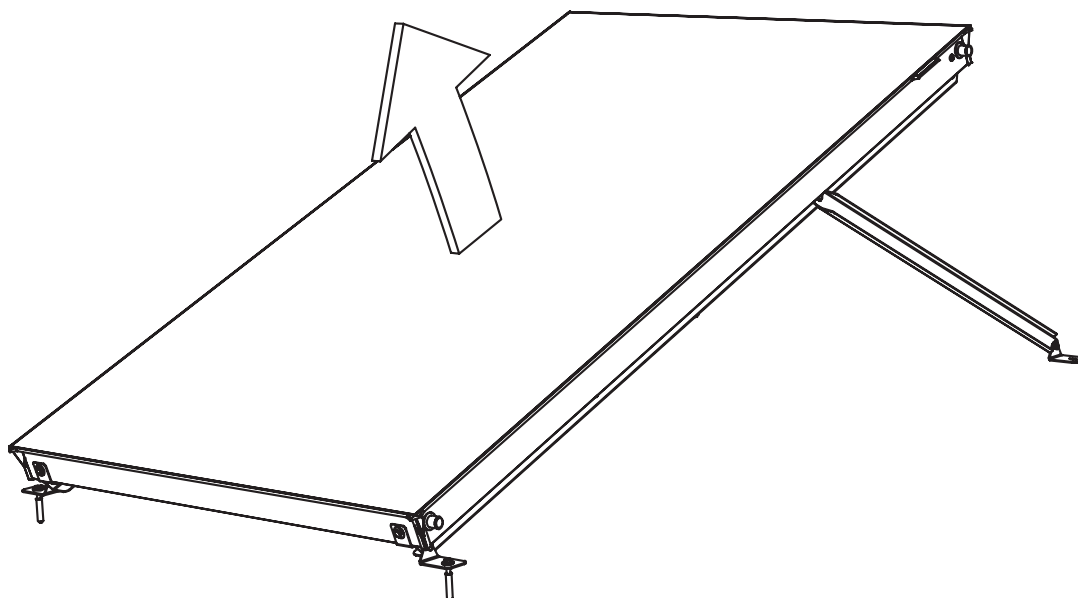

24 INSTALLATION

STAND-ALONE COLLECTOR FLAT ROOF**STEP 7**

Temporarily secure the collector in position and ensure that the support struts are parallel. Mark and drill appropriate holes on the roof surface.

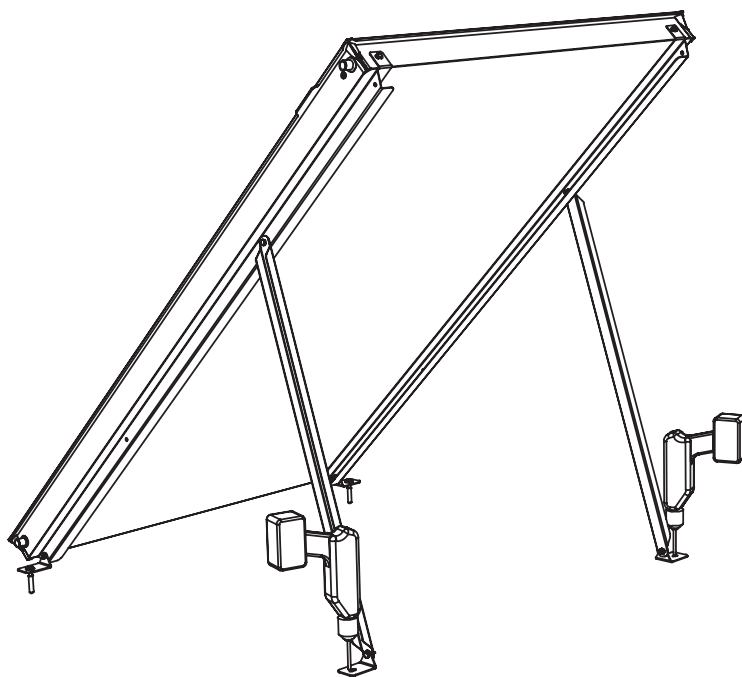
**STEP 8**

Install the appropriate anchors at the rear feet. Appropriately seal for moisture and water ingress according to the roof material and operating conditions. Check all bolts for tightness. Check the system for any movement.

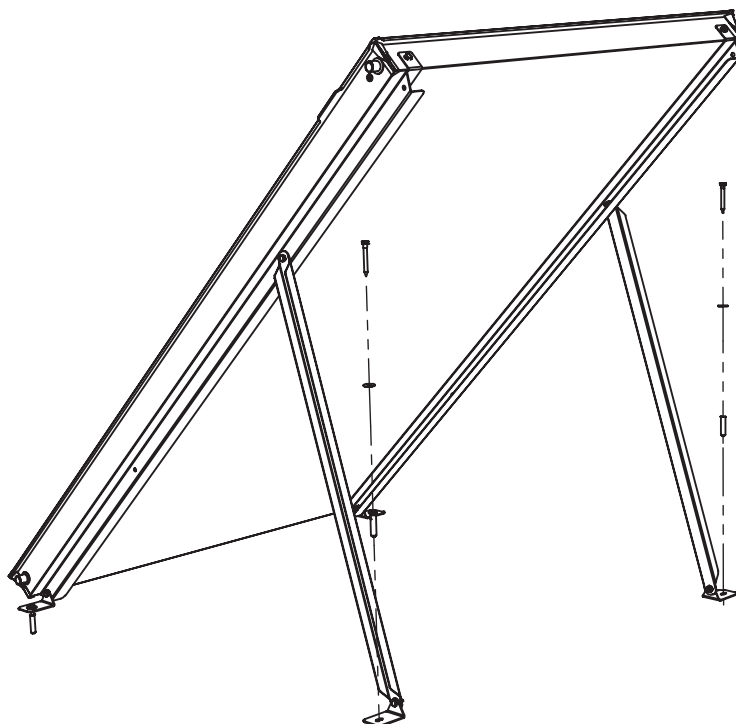

⚠ Do not remove the collector cover! Remove only after the collector has been connected and filled with thermal fluid.

25 INSTALLATION

STAND-ALONE COLLECTOR FLAT ROOF WITH ARRAY

STEP 1

Assemble the right and left side sub-assemblies of the first collector as shown in the figure.

Note the double brackets at the left side where the second collector will be attached. Tighten the bolts so that movement is possible.

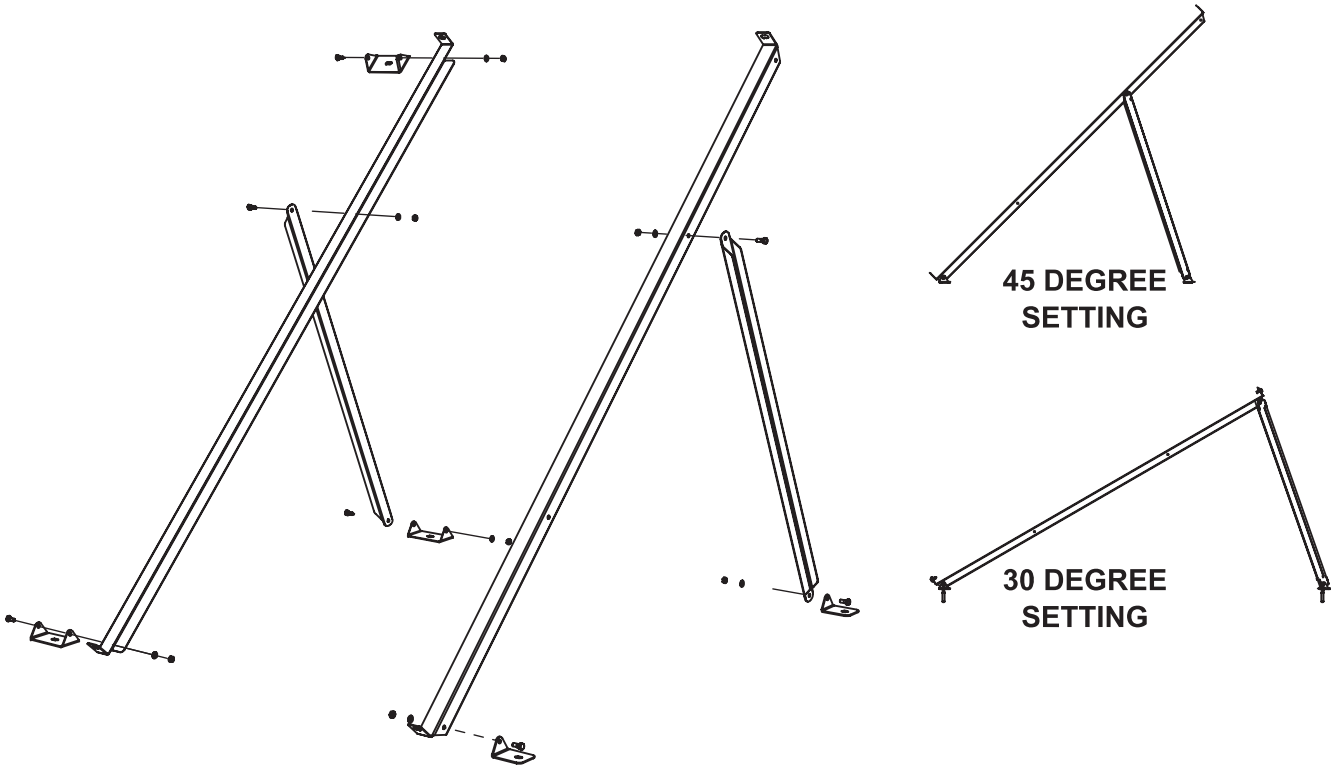

STEP 2

Determine the position of the array system on the roof according to the guidelines at the relevant section of this manual. The array is built by installing the units successively and moving in one direction. Determine where the first collector will be installed and mark the position of the holes for the front two feet at 1255mm apart. Drill appropriate holes for the anchors. In the figure above the array is built from right to the left.

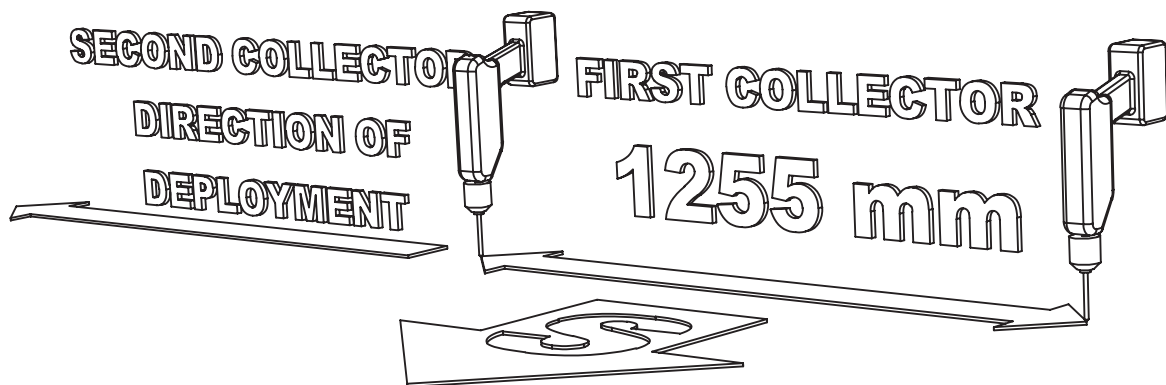

26 INSTALLATION

STAND-ALONE COLLECTOR**STEP 3-8**

Follow steps 3-8 in the previous section to install the first collector.

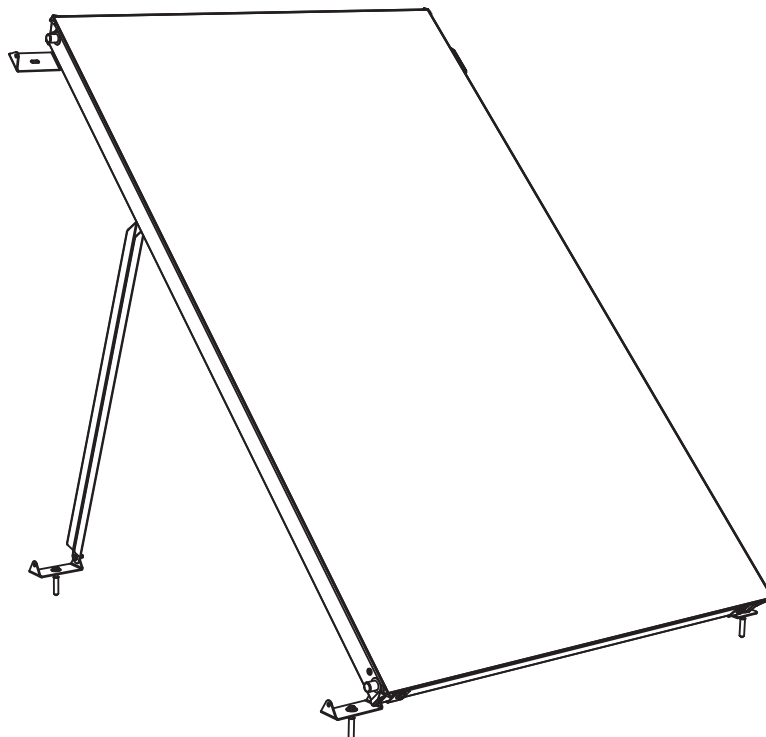
**STEP 9**

Install the next collector rail sub-assembly as shown in the figure above and tighten the bolts.

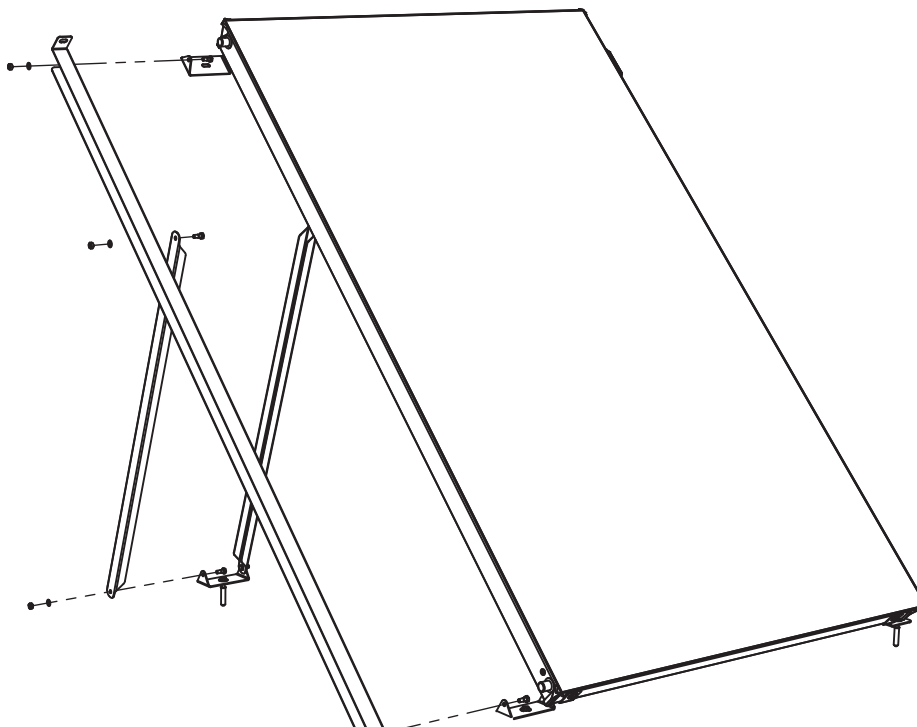

⚠ Do not remove the collector cover!

27 INSTALLATION

STAND-ALONE COLLECTOR**STEP 10**

Install the next rail subassembly onto the opposing side of the next collector. Install the male to male hydraulic connections on the adjacent side of the collector.

NOTE: In the case this is not the final collector in the array, double feet need to be installed as shown in STEP 1.

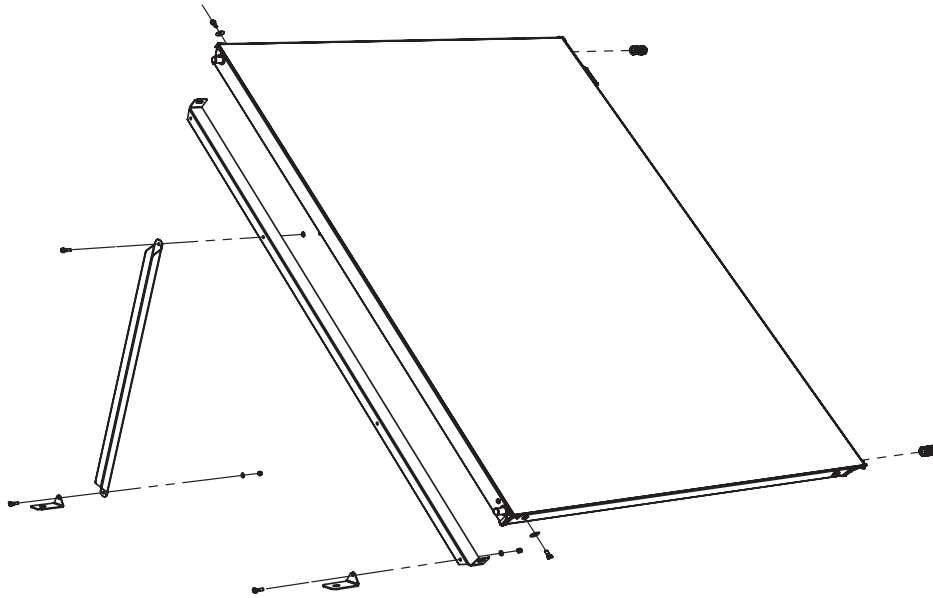
**STEP 11**

Slide the second collector carefully into place. Use the installed rail as a guide and insert the hydraulic connections into the tubes. Exercise caution not to exert forces on the tubes thus damaging the absorber. Install the collector bolts, tighten the hydraulic fittings and tighten the collector bolts.

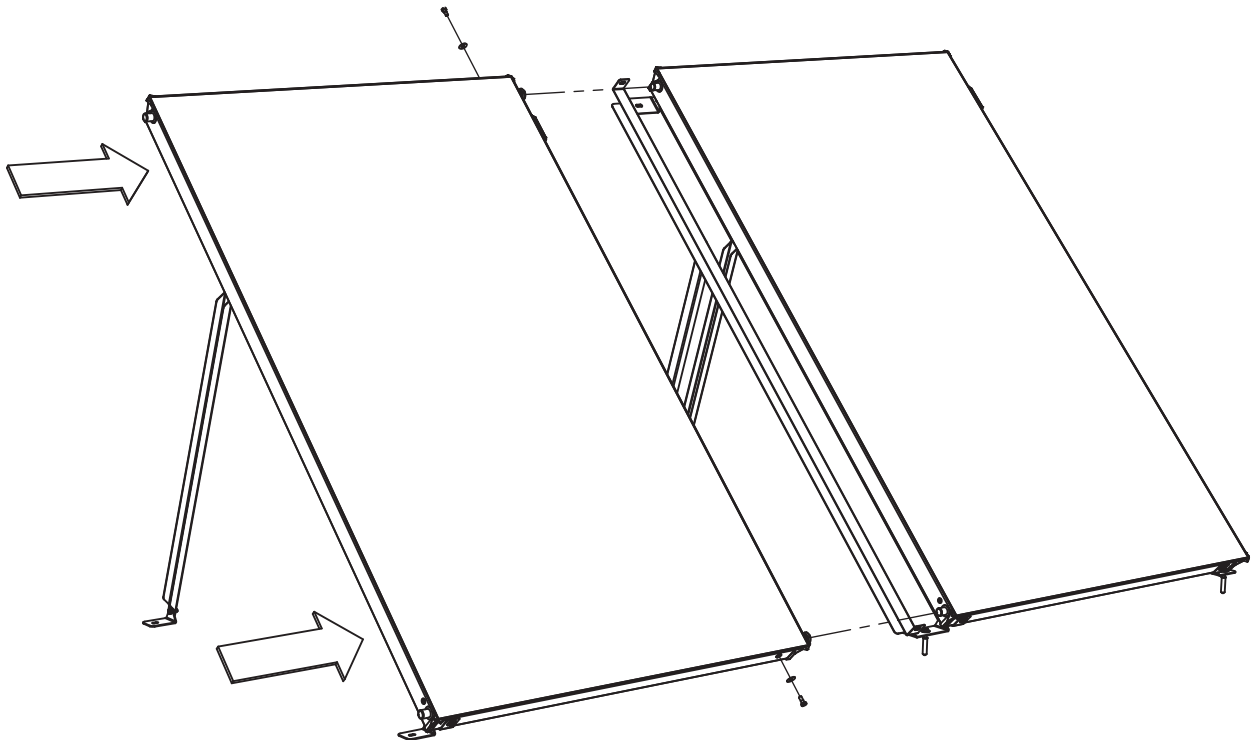

⚠ Do not remove the collector cover!

28 INSTALLATION

STAND-ALONE COLLECTOR**STEP 12**

Adjust if necessary the position of the feet so that they are in line with the rest. Mark and drill holes for the installation of the anchors.

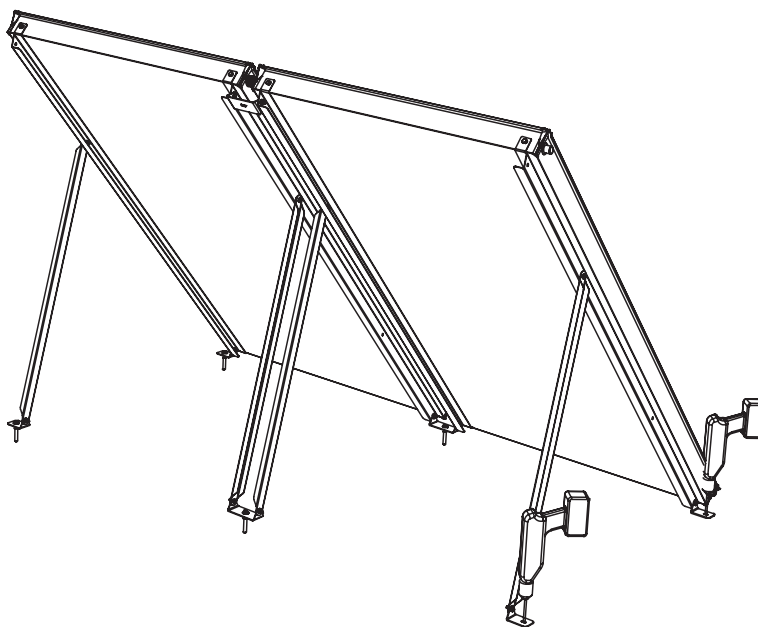
**STEP 13**

Install the anchors and tighten. When the installation of the array is finished seal all anchors for moisture and water ingress by appropriate means for the roof material and operating conditions.

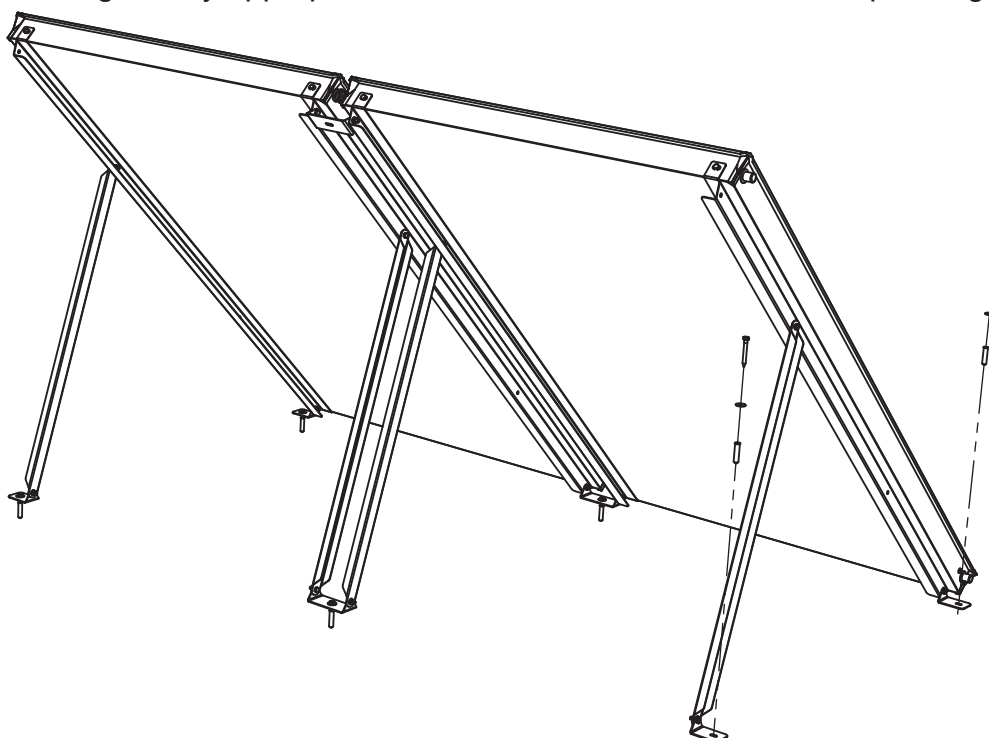

⚠ Do not remove the collector cover!

Diameter of connection pipes for a specific flow rate of 50 lt/m²h

Total surface area (m ²)	2 - 4	6 - 12	14 - 20
Diameter of copper pipe (mm)	12 - 16	18-22	22-35

⚠ Do not fix the ends of lines of solar collectors rigidly: leave them free to absorb thermal expansion. If this is not possible, fit an expansion joint at each end.

29 SOURCE WATER SYSTEM

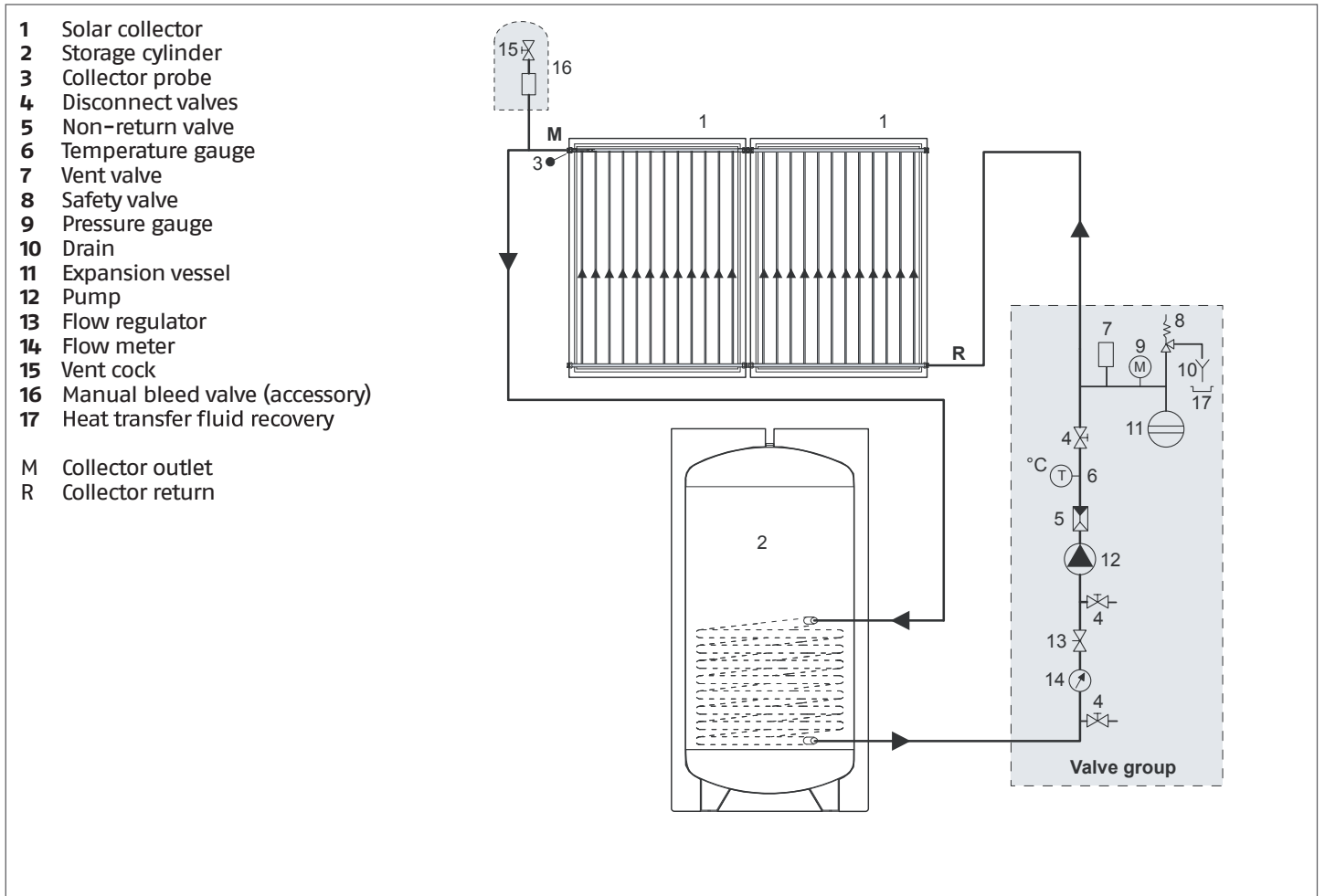

- ⚠** If copper pipes are used, joints must be hot brazed.
- ⚠** We recommend the use of stainless steel pipes specially made for solar collectors for the outlet, return and probe pipes. The probe cable should be of the shielded type.
- ⚠** Do not use plastic or multistrata pipes. Operating temperature can exceed 180°C.
- ⚠** Pipe lagging must be able to resist high temperatures (180°C)

30 FILLING AND EMPTYING

Before system commissioning it is necessary to wash and fill it.

Solar collectors are exposed to the risk of frost during winter, as they are installed outdoor. Moreover, they can reach high temperatures in stagnation conditions, consider these things when choosing the heat transfer fluid.

⚠ If copper piping has been used and joints have been hot brazed, flush out the system to remove any brazing residues. Seal test the system after you have flushed it out. Fill the solar collector with glycol/water mix immediately after flushing it out, because flushing water may remain trapped in the circuit (with a consequent risk of freezing).

⚠ For system washing, filling and emptying, follow the instructions contained in the manual of the matched solar station.

⚠ Filling, emptying and venting must be carried out with collectors at ambient temperature and protected from solar radiation.

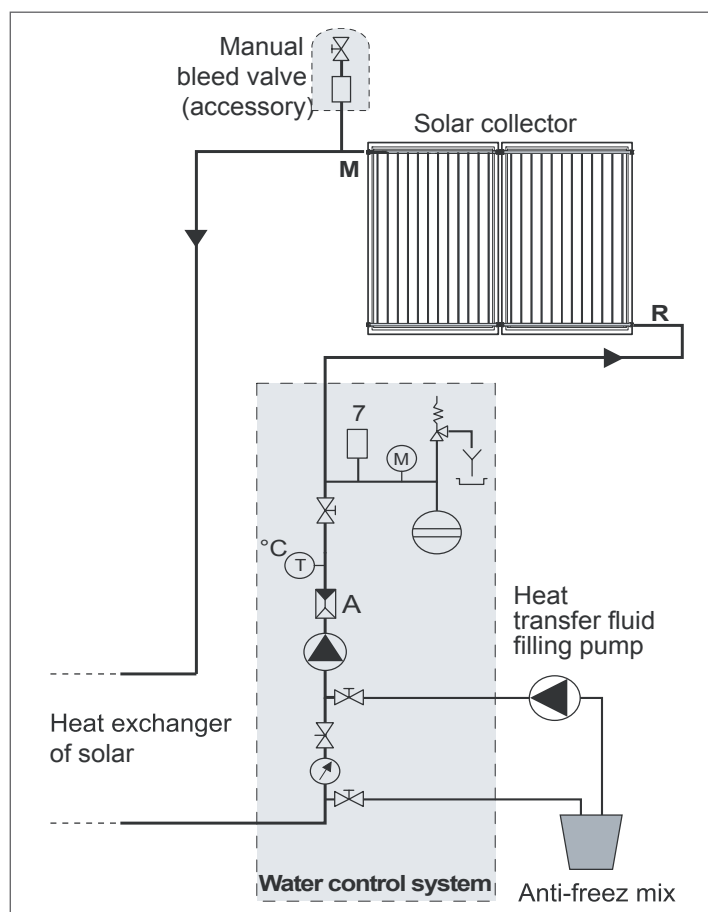

31 DEVICE CLEANING AND MAINTENANCE

⚠ The following operations must be exclusively performed by Technical Assistance Service

It is recommended to clean the glass once a year, as the deposit of dust and leaves reduces system efficiency. The collector must be cleaned with water or water and soap. Dry the collector at the end of cleaning operations.

⊘ Do not use abrasive products, petrol or triethylene.

The heat transfer fluid must be checked every 2 years to verify the effectiveness of water and glycol mix, including its pH value.

- Check the antifreeze with the suitable instrument - refractometer or hydrometer- (nominal value approx. -30°C): if the limit value of -26°C is exceeded, replace or top-up the antifreeze.
- Use litmus paper to check the pH (nominal value approx. 7.5). If the measured value is below 7, change the heat transfer liquid.

Check the integrity of insulation and expansion joints.

32 RECYCLING AND DISPOSAL

The device is primarily composed of:

At the end of the device's useful life, these components must be separated and disposed of according to current regulations in the country of installation.

Material	Component
Glass (low iron, mistlite, tempered)	Cover
Brass - Copper - Aluminium	Absorber
Rock wool	Insulation
AlloySteel	External frame
Colofast	Sealing elements of connections

END USER INSTRUCTIONS

Refer to the GENERAL SAFETY INFORMATION and PRECAUTIONS section for safety-related information.

33 EXTERNAL MAINTENANCE

It is recommended:

- To clean the glass once a year, as the deposit of dust and leaves reduces system efficiency
- To check the heat transfer fluid to verify its effectiveness every two years
- To check the integrity of solar collector insulations and any expansion joints, every two years.

For cleaning operations and solar collector efficiency check, contact the nearest Technical Assistance Service.

The manufacturer strives to continuously improve all products. Appearance, dimensions, technical specifications, standard equipment and accessories are therefore liable to modification without notice.