

R701F



Energy
Management

Ball valve with built-in filter, full port

Datasheet
1041EN 02/2021



Ball valve with built-in filter, female-female threaded connections and full port.

Valve R701F is the ideal solution for hydraulic systems requiring installation of a filter and shut-off valves in limited space (for example, upstream of energy meters, circulators and/or on boilers and heat pump inlets.)

➤ Versions and product codes

PRODUCT CODE	CONNECTIONS	BRASS TYPE	HANDLE TYPE	HANDLE COLOR
R701FY023	G 1/2"F x G 1/2"F	UNI EN 12165 CW617N	T-handle	Red
R701FY024	G 3/4"F x G 3/4"F	UNI EN 12165 CW617N	T-handle	Red
R701FY025	G 1"F x G 1"F	UNI EN 12165 CW617N	T-handle	Red
R701FY112	Rc 3/8" x Rc 3/8"	"DZR" UNI EN 12165 CW602N	T-handle	Red
R701FY113	Rc 1/2" x Rc 1/2"	"DZR" UNI EN 12165 CW602N	T-handle	Red
R701FY114	Rc 3/4" x Rc 3/4"	"DZR" UNI EN 12165 CW602N	T-handle	Red
R701FY115	Rc 1" x Rc 1"	"DZR" UNI EN 12165 CW602N	T-handle	Red

➤ Benefits and main characteristics

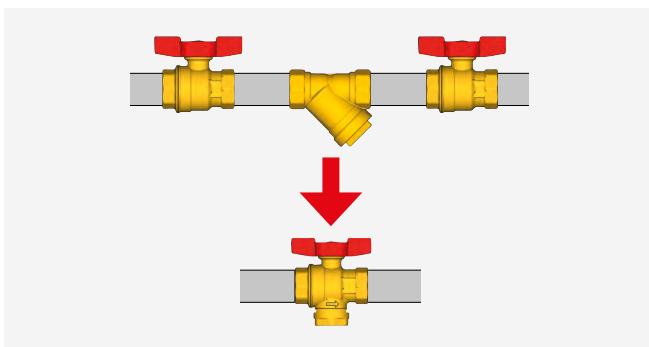

- **Very reduced dimensions** as 3 hydraulic components (1 filter and 2 shut-off valves) are integrated in a single valve.

- **Minimum chance of error.** The filter includes a plastic groove that, after cleaning and maintenance, guides it into the valve in one direction only.

- **Easy to clean.** To clean the filter it is only necessary to close the ball valve, loosen the cap and manually remove the filter to clean it.

➤ Technical data

Main features and materials

- Suitable for water for heating/cooling systems and glycol-based solutions (max. 50 %)
- Full port
- Valve made of UNI EN 12165 CW617N brass, or "DZR" UNI EN 12165 CW602N brass, depending on versions
- Stem with double O-Ring
- Nut with anti-corrosion coating, with guarantee seal and hologram
- Aluminium T-handle, red painted
- AISI 304 stainless steel filter: filtering capacity 500 µm

Field of applications

- Temperature range: 5÷110 °C
- Max. working pressure at 20 °C with water: 3,2 MPa (32 bar)

➤ Components

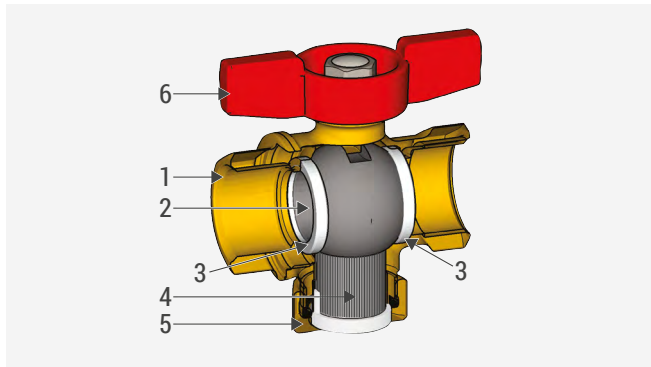

1 Valve body

2 Ball

3 Gasket

4 Metallic filter

5 Cap

6 T-handle

➤ Operation

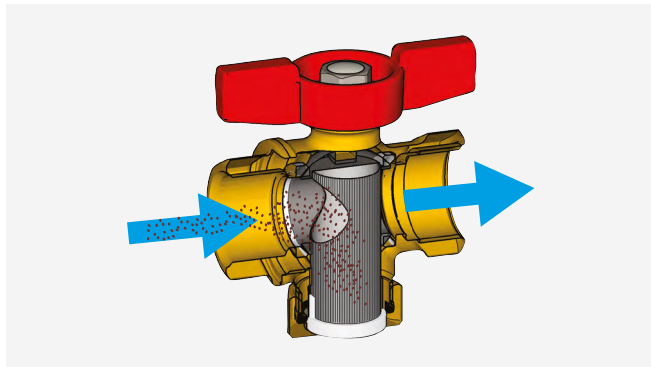

When the valve is open the heat transfer fluid flows through the filter, then it slows down to enable the separation of solid debris.

Impurities are filtered when colliding with the metallic mesh and fall on the bottom of the cap.

The special structure of the valve body enables to exploit the entire filtering surface, extending the operation time before the mesh is completely filled with dirt.

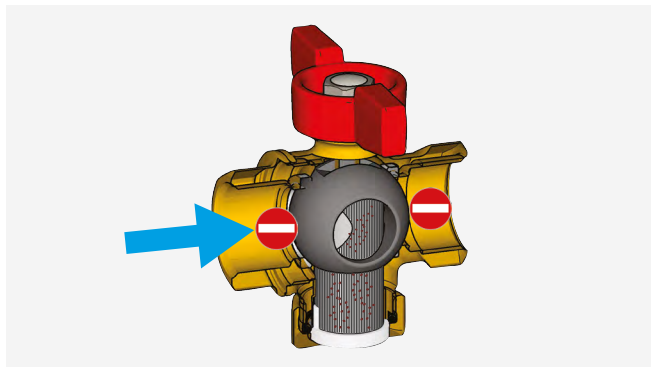

When the valve is closed the heat transfer fluid cannot flow through the filter as this is isolated from the rest of the hydraulic circuit.

In this position, one can loosen the bottom cap and remove the filter to rinse it with clean water and recover the filtering surface.

➤ Installation

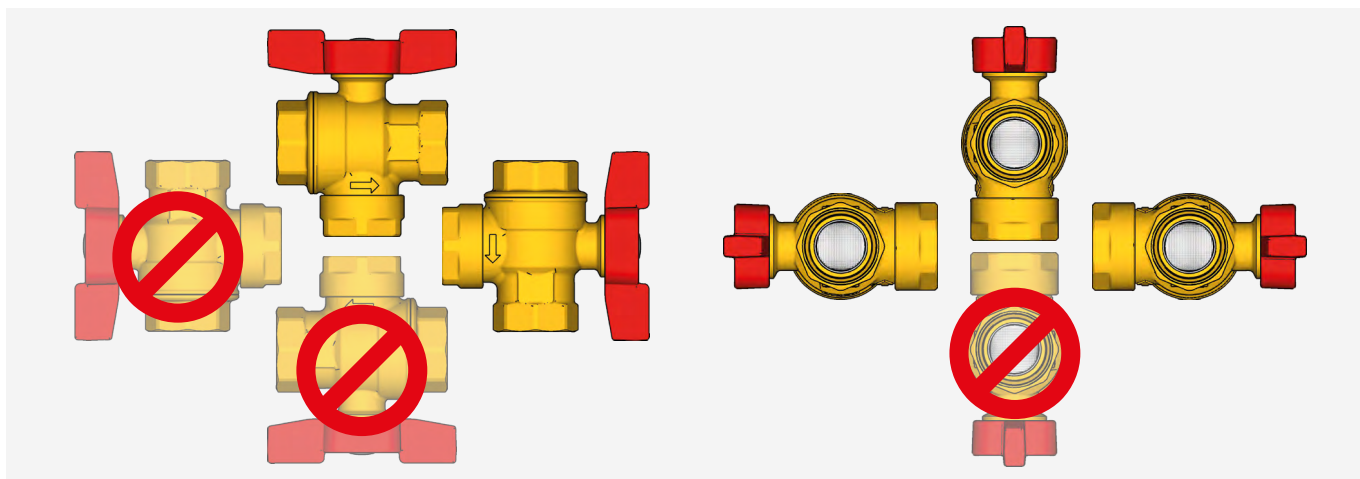

⚠ WARNING. Before installing the filter, we recommend checking the system working conditions, such as pressure and temperature, to make sure they are set within the operational range. Access to the filter must be free from obstacles for maintenance purposes.

➤ Maintenance

Perform maintenance of the valve with filter based on the quantity of impurities present in the fluid used. We recommend cleaning the filter at least once a year to prevent, in addition to an excessive reduction of the system flow rates, irreversible scales that may require the replacement of the filtering mesh.

Follow the steps below to clean the metallic mesh:

- Close the valve ball turning the T-handle.
- Loosen the octagonal cap using a proper wrench (see paragraph "Dimensions").
- Remove the filter and rinse it under running water and using a plastic bristle brush. Make sure the filtering surface is fully recovered (replace the filter in case of irreversible obstructions or breaks).
- Reinstall the filter in the valve making sure the filter hole (ref. "A") is pointing in the direction opposite to the flow, shown by an arrow on the valve body (ref. "B")
- Manually close the hexagonal cap (max 10 Nm) and open the valve by turning the T-handle.

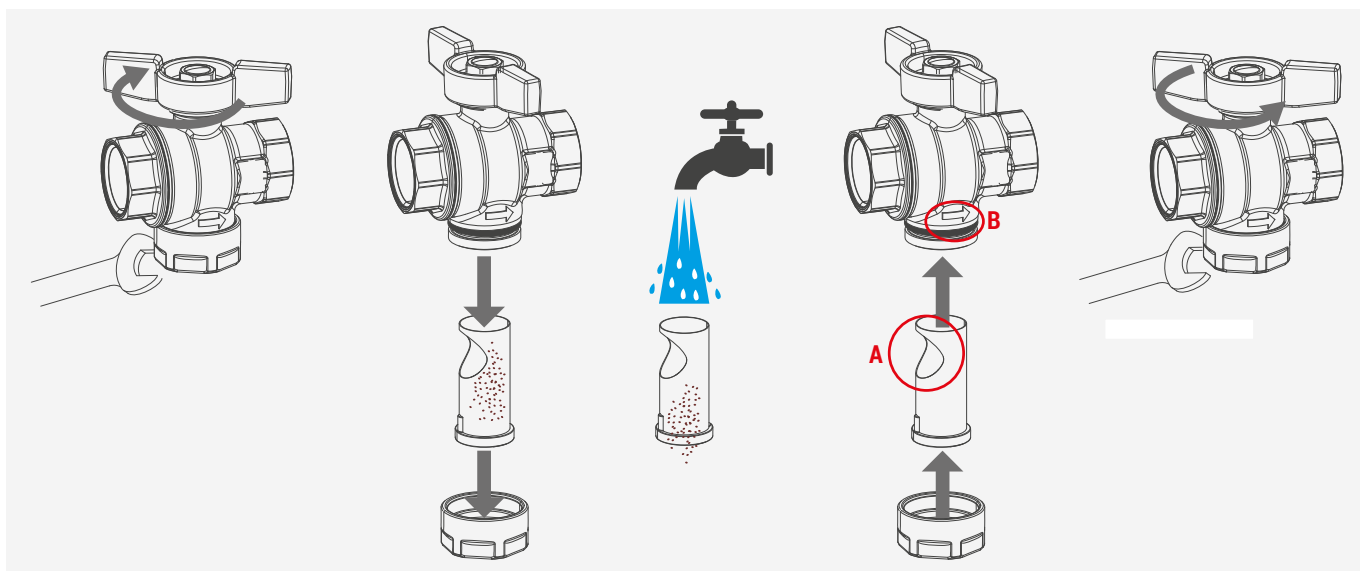

⚠ WARNING. After filling the system, we recommend cleaning the filter for the first time after a week of use to remove any obstruction caused by installation residues (metallic chips, seal elements.)

➤ Dimensions and Kv

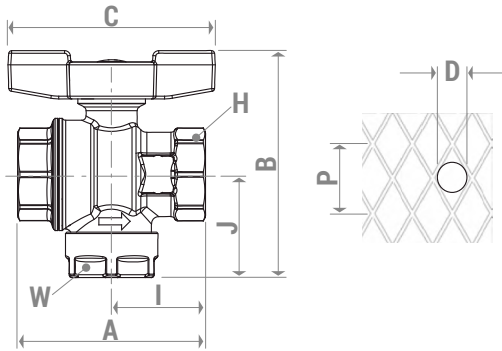

PRODUCT CODE	CONNECTIONS	DN	A [mm]	I [mm]	B [mm]	J [mm]	C [mm]	H [mm]	W [mm]	P [mm] Hole pitch	D [μm] Diameter of inscribed hole	N Number of holes per cm ²	Kv
R701FY023	G 1/2" F x G 1/2" F	15	59	30	69	31	63	wr.25	wr.27	1	500	70	2,5
R701FY024	G 3/4" F x G 3/4" F	20	66	33	80	36	73	wr.31	wr.30	1	500	70	4,6
R701FY025	G 1" F x G 1" F	25	79	40	94	46	73	wr.38	wr.40	1	500	70	10,0
R701FY112	Rc 3/8" x Rc 3/8"	10	59	30	69	31	63	wr.25	wr.27	1	500	70	2,0
R701FY113	Rc 1/2" x Rc 1/2"	15	59	30	69	31	63	wr.25	wr.27	1	500	70	2,5
R701FY114	Rc 3/4" x Rc 3/4"	20	66	33	80	36	73	wr.31	wr.30	1	500	70	4,6
R701FY115	Rc 1" x Rc 1"	25	79	40	94	46	73	wr.38	wr.40	1	500	70	10,0

➤ Product specifications

R701F

Ball valve with built-in filter, female-female connections. Suitable for water for heating/cooling systems and glycol-based solutions (max. 50 %). Valve made of UNI EN 12165 CW617N brass or "DZR" UNI EN 12165 CW602N brass, depending on versions. Full port. Aluminium T-handle, red painted. Stem with double O-Ring. Nut with anti-corrosion coating, warranty seal and hologram. AISI 304 stainless steel filter: filtering capacity 500 μm. Temperature range: 5÷110 °C. Max. working pressure at 20 °C with water: 3,2 MPa (32 bar).

⚠ Safety Warning. Installation, commissioning and periodical maintenance of the product must be carried out by qualified operators in compliance with national regulations and/or local standards. A qualified installer must take all required measures, including use of Individual Protection Devices, for his and others' safety. An improper installation may damage people, animals or objects towards which Giacomini S.p.A. may not be held liable.

♻ Package Disposal. Carton boxes: paper recycling. Plastic bags and bubble wrap: plastic recycling.

ℹ Additional information. For more information, go to giacomini.com or contact our technical assistance service. This document provides only general indications. Giacomini S.p.A. may change at any time, without notice and for technical or commercial reasons, the items included herewith. The information included in this technical sheet do not exempt the user from strictly complying with the rules and good practice standards in force.

♻ Product Disposal. Do not dispose of product as municipal waste at the end of its life cycle. Dispose of product at a special recycling platform managed by local authorities or at retailers providing this type of service.