

# Under-boiler magnetic filter

## Caleffi XS<sup>®</sup>

**5459 series**



01357/19 GB



### Function

The Caleffi XS under-boiler magnetic filter mechanically separates the impurities in heating and air conditioning systems by means of a mesh strainer, a neodymium magnet and a collection chamber for the heaviest particles. The chamber has transparent windows, allowing the user to check whether the internal elements need to be cleaned. Its very small dimensions make it suitable for all generator types.

PATENT PENDING

### Product range

Code 545900 Under-boiler magnetic filter size DN 20 (3/4")

### Technical specifications

#### Materials

Body: brass EN 12165 CW617N, chrome-plated  
 Fitting: brass EN 12165 CW617N, chrome-plated  
 Hydraulic seals: EPDM  
 Strainer container: PA 12  
 Magnet holder cap: PA6G30  
 Filter: stainless steel EN 10088-2 (AISI 304)  
 Ball: brass EN 12165 CW617N, chrome-plated  
 Ball valve lever: PA66G30

#### Performance

Medium: water, non-hazardous glycol solutions  
 Maximum percentage of glycol: 30 %  
 Maximum working pressure: 3 bar  
 Working temperature range: 0–90 °C  
 Strainer mesh size: 800 µm  
 Magnetic induction of magnet: 0,475 T  
 Kv: 3,55 m<sup>3</sup>/h

#### Connections

- boiler side: 3/4" M (ISO 228-1)
- system return side: 3/4" M (ISO 228-1)
- dual captive nut fitting (supplied): 3/4" F (ISO 228-1) - 3/4" F (ISO 228-1)

### Dimensions

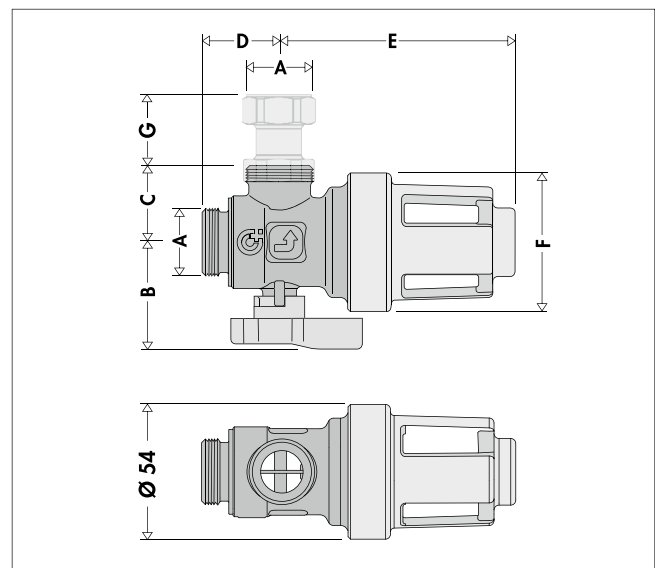

Code	A	B	C	D	E	F	G	Mass (kg)
545900	3/4"	41,5	30	32,2	94	54	25	0,53

## Operating principle

Magnetic filter operation is based on three principles:

- the mechanical filtration provided by the steel mesh captures the impurities
- the magnetic field separates ferrous particles
- a large separating chamber allows the dirt to settle

The special deflector profile directs impurities in the water and makes them precipitate in the separating chamber, where they are collected. The magnet, which is positioned so that the flow hits it head-on, effectively separates the ferrous particles. The 800 µm filter mesh captures the remaining impurities.

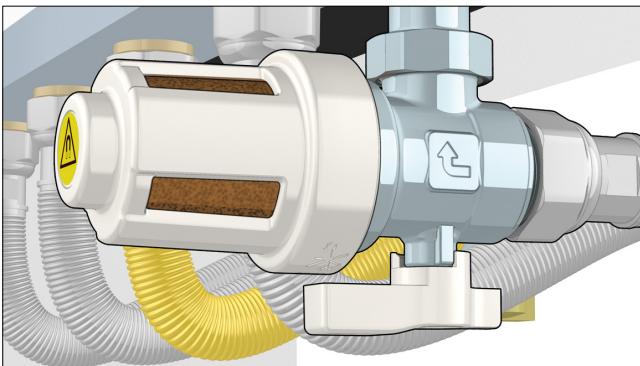
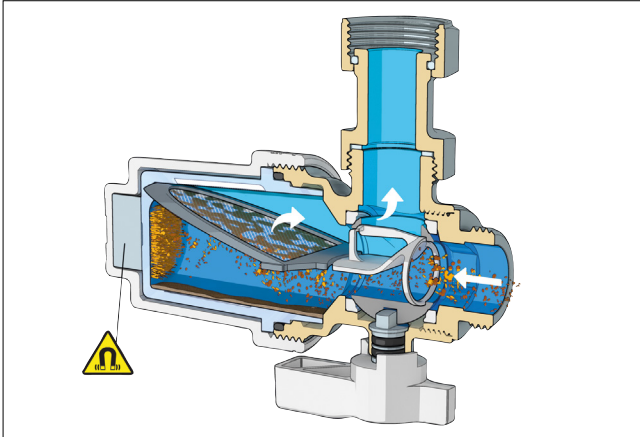

The chamber has transparent windows, so it is easy to check if the internal elements need to be cleaned at any time, and clean them only when strictly necessary.

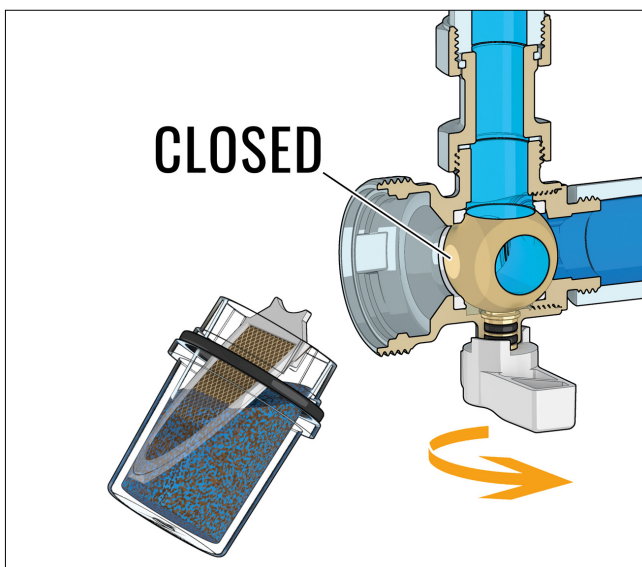

The shut-off valve has been specially designed so that only the water contained in the dirt separator needs to be drained before cleaning the internal elements.

## Construction details

### Design

The special white and chrome-plated finish means that the dirt separator easily adapts to the domestic environment.

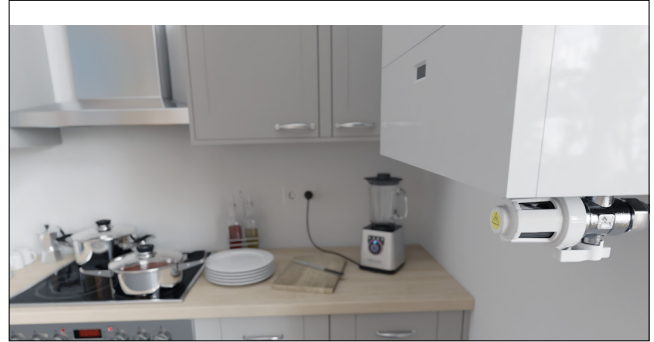

Its very small dimensions make it suitable for all generator types, whether installed in new or requalified systems.

### Neodymium magnet

The neodymium magnet is positioned so that the flow hits it head-on, very effectively attracting the metal particles. The magnet is not in direct contact with the medium, making it easy to clean.

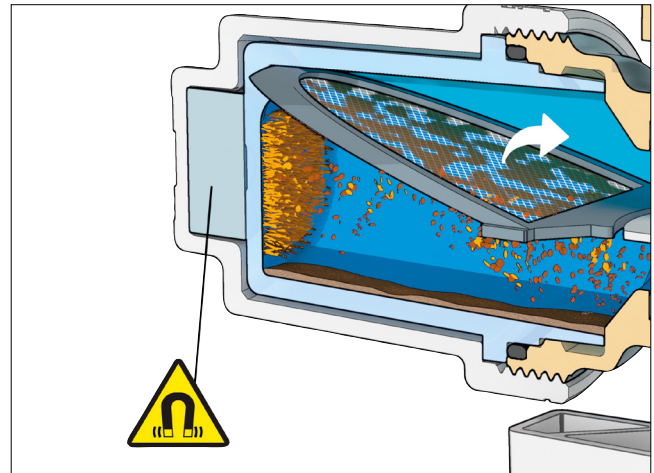

## Hydraulic characteristics

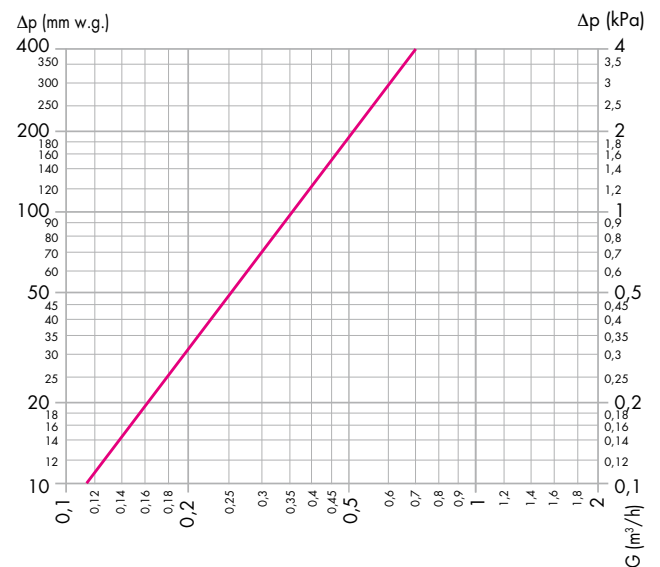

**Kv (with clean filter): 3,55 m³/h**

**Maximum recommended flow rate: 800 l/h**

## Installation

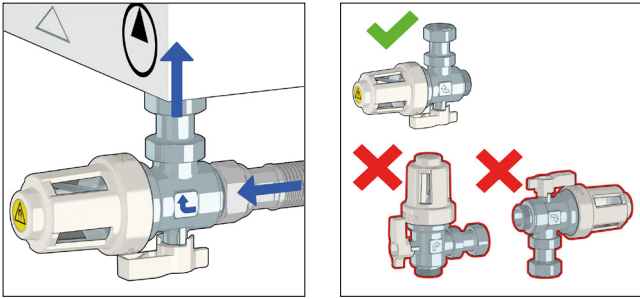

The dirt separator should always be installed horizontally.

The tailpiece with captive nut provided allows the dirt separator to be connected directly to the boiler using, for example, a flexible coupling.

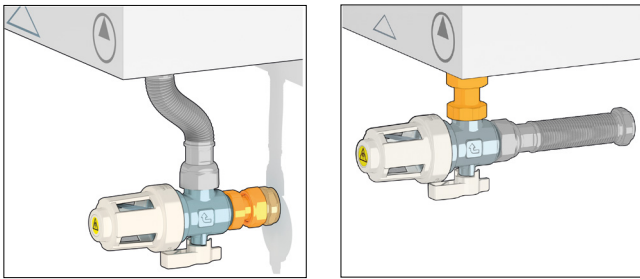

## Maintenance

After checking how clogged the dirt separator is, it can be cleaned with a few simple steps after isolating it with the dedicated ball valve. The filtering cartridge can be washed with running water.

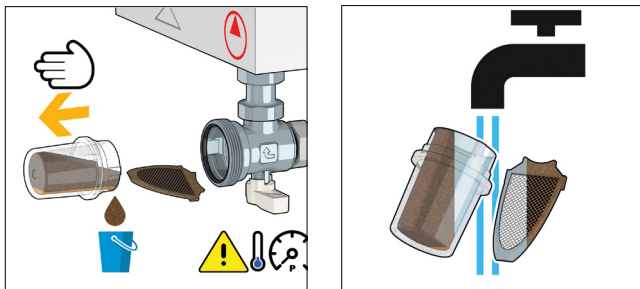
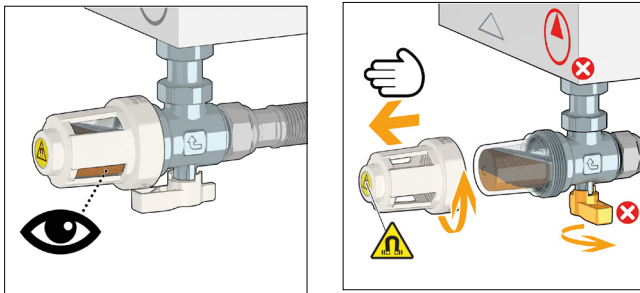

## Using additives and flushing with kit F0001037 (optional)

The dirt separator can be used as an access point for injecting the circuit with chemical additives designed to wash and protect the system, by means of the special kit.

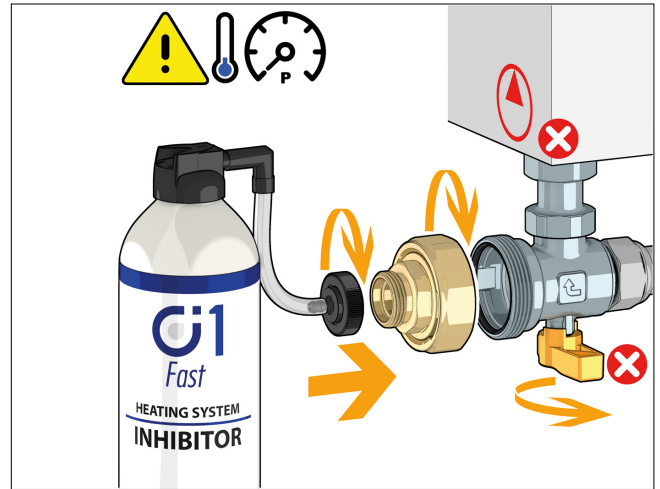

## Flushing

The dirt separator can also be used to flush the system, using the hose connection supplied with the kit.

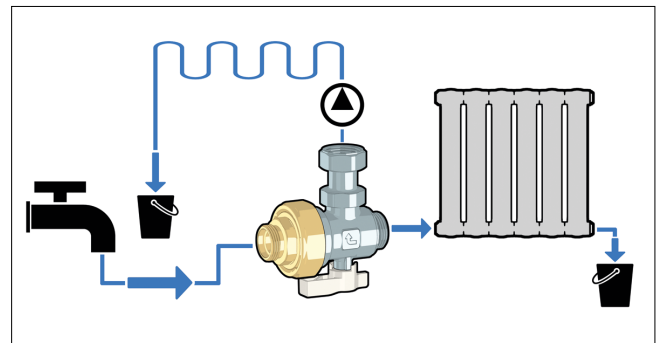

---

## SPECIFICATION SUMMARY

---

### Code 545900

Caleffi XS under-boiler magnetic filter. Body made of chrome-plate brass EN 12165 CW617N, Fitting made of chrome-plated brass EN 12165 CW617N. 3/4" M ISO 228-1 boiler side connections, 3/4" M ISO 228-1 system return side fittings, 3/4" F - 3/4" F fitting with dual captive nut (supplied). EPDM hydraulic seals. Strainer container made of PA 12. Magnet holder cap made of PA6G30. Filter made of stainless steel EN 10088-2 (AISI 304). Ball made of chrome-plated brass EN 12165 CW617N. Ball valve lever made of PA66G30. Medium can be water and glycol solutions, maximum glycol percentage 30 %. Maximum working pressure 3 bar. Working temperature range 0–90 °C. Strainer mesh size 800 mm. Magnetic induction of magnet 0,475 T.

---

*We reserve the right to make changes and improvements to the products and related data in this publication, at any time and without prior notice.*

---